

microsonic dbk-5 Ultrasonic double-sheet detection

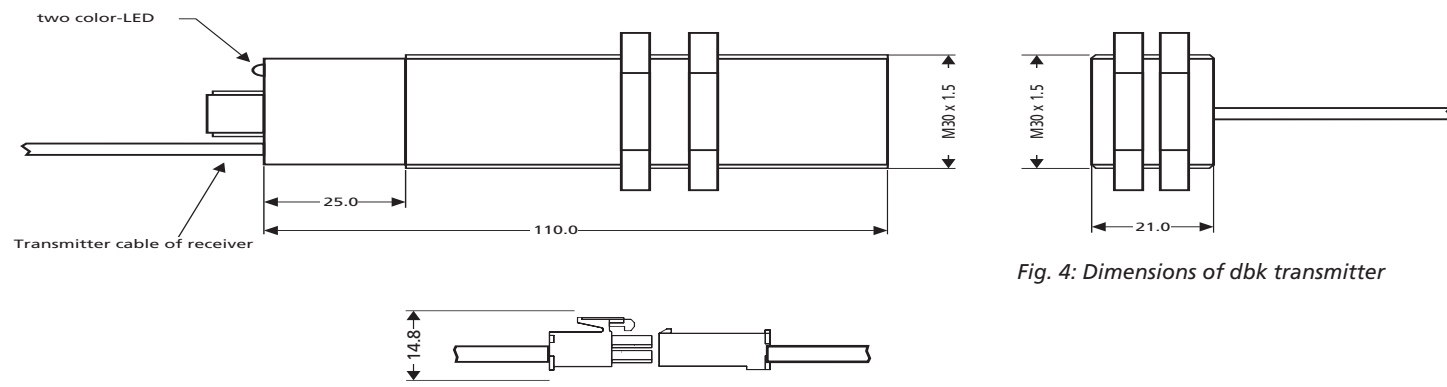

Fig. 3: Dimensions of dbk receiver

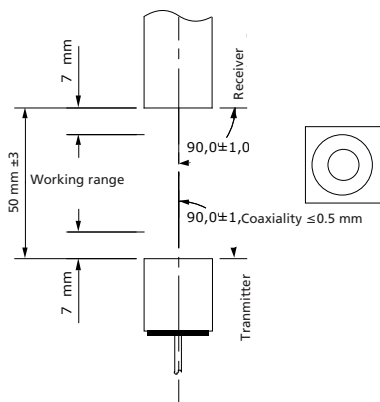

Fig. 5: Installation and working range

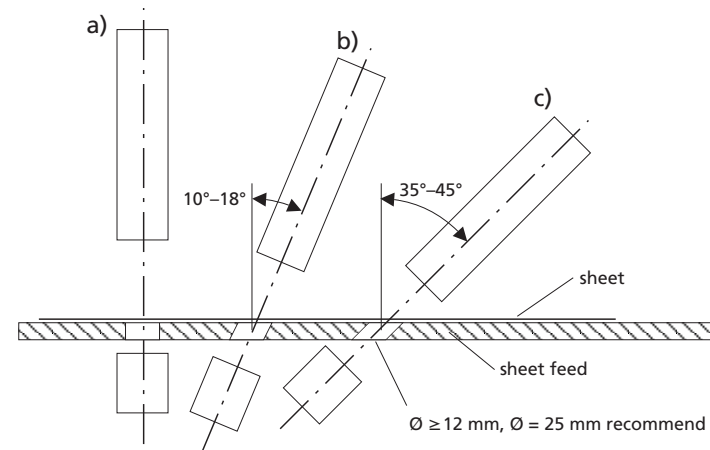

Fig. 6: Installation positions

Material and material thickness	0°	10°- 18°	35°- 45°
Paper with weights from 120 g/m ²	■		
thin sheet metals up to 0.4 mm thick	■		
PCB-Boards >> 1.5 mm thick		■	
sheet metals up to 0.4 mm thick		■	
PCB-Boards up to 1.5 mm thick		■	
corrugated card			■

Fig. 7: Recommend installation position

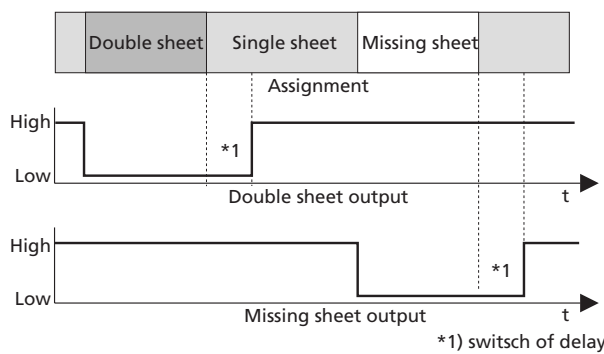

Fig. 8: dbk-5/CDD/O/M30 time diagram Free-Run-Mode

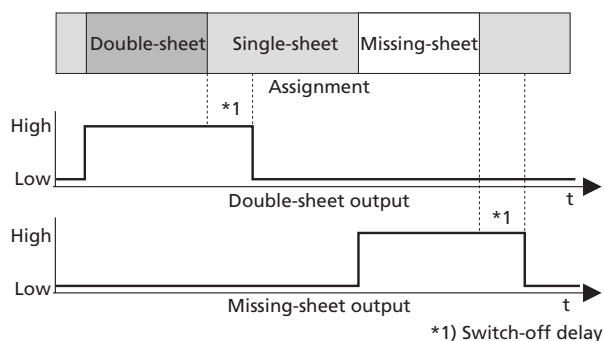

Fig. 9: dbk-5/CEE/O/M30 time diagram Free-Run-Mode

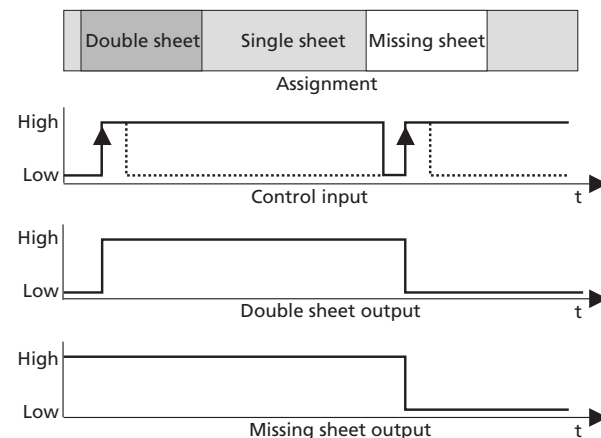

Fig. 10: dbk-5/BDD/O/M30 time diagram Trigger-Mode



Fig. 4: Dimensions of dbk transmitter

Operating Manual

dbk-5/CDD/O/M30 E+S dbk-5/CEE/O/M30 E+S dbk-5/BDD/O/M30 E+S

- Does not need to be calibrated for the sheet material
- Checks sheet metal up to 0.7mm thick
- Scanning of corrugated card
- Plastic sheets up to a thickness of several millimeters
- Double-sheet and missing-sheet output
- Double-sheet and missing sheet response time from 600µs
- Compact design in M30 threaded sleeve

Operating principle

The purpose of the double-sheet detector is to detect two or more sheets that are lying one on top of the other. The sensor system consists of a transmitter and a receiver with integrated evaluation electronics.

An ultrahigh-frequency ultrasonic transmitter fires a sonic beam at the underside of the sheet. The beam causes the sheet to vibrate, which in turn causes a very small sound wave on the other side of the sheet. This sound wave is then evaluated by the ultrasonic receiver opposite. If there are two sheets one on top of the other ("double sheet"), then the signal is weakened to such an extent that it hardly reaches the receiver.

- Typical materials in the range of the dbk-5 are
- sheet metal up to approx. 0.7 mm thick depending on the type of metal.
 - plastic sheets
 - boards for the printed circuits up to a thickness of several millimeters
 - corrugated card

The maximum thickness of material that can be reliably detected as a double-sheet, depends on the properties of the material. The maximum thickness must be determined by trials.

The ultrasonic double-sheet detector is equipped with a control input that, depending on the particular model, is used to select different response times or to activate and deactivate the detector.

The control input enables the following operational modes for the two different models.

- **dbk-5/CDD/O/M30 E+S, dbk-5/CEE/O/M30 E+S (Free-Run-Mode)**
The ultrasonic double-sheet detector operates continuously. In the event of a double sheet or missing sheet, the corresponding output is set following the response time. When the error is cleared, the output is reset after the tripping delay.
- **dbk-5/BDD/O/M30 E+S (Trigger-Mode)**
One scan is performed with a rising edge at the control input (edge change -U_B to +U_B). After the response time of 600µs, both outputs are set in accordance with the result of the scan.

Important information for installation and application

When installing, starting up or carrying out maintenance work on the detection system, always perform all measures essential to ensuring the safety of staff and the system (cf. the instruction manual for the entire system and the instructions of the system operator). The double-sheet detectors of the dbk series have been designed for industrial applications.

The sensors are not items of safety equipment and must not be used for the purposes of personnel safety and machine protection.

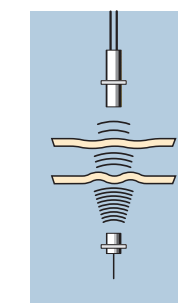

Fig. 1: Operating principle

Installation

- Install the transmitter and receiver facing each other 50 mm ± 3 mm apart (see fig. 5). Installation of the dbk is not dependent on the position.

Notes!

- The distance between the transmitter/receiver and the passing sheet must never be less than 7 mm.
- The coaxiality must be ≤ 0.5 mm.
- Angular deviation between the transmitter and the receiver must be no more than 2°.
- When working with papers and sheet metals up to 0.4 mm, we recommend you to install the dbk perpendicular to the sheet (see fig. 6 a).
- In the case of thicker sheet metals and boards for printed circuits it is preferable to mount the dbk-5 at an angle of 10°-18° to the sheet. The optimum angle should be determined by way of trials.
- Corrugated cards should be scanned at an angle of 35°-45° to the corrugations.
- The maximum tightening torque for the nuts is 15 Nm.
- If you install the transmitter in a recessed position or position a sheet guide between the transmitter and receiver, the hole must have a minimum diameter of ≥ 12 mm, but we recommend a diameter of 18 mm (fig. 6).

- Connect the transmitter to the receiver using the 2-pin plug-in connector.

Notes!

- The cable between the transmitter and receiver must not be connected to an external voltage.
- Connect the 4-core or 5-core control cable of the receiver as shown in fig. 2.

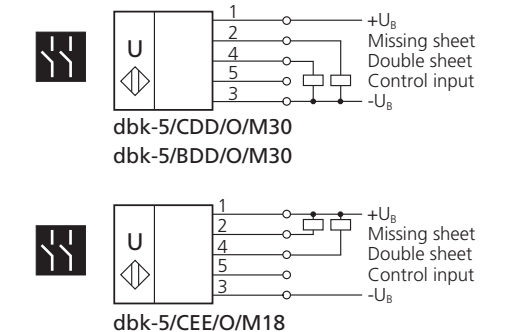

Fig. 2: Standard symbols and terminal assignment

microsonic dbk-5
Ultrasonic double-sheet detection

Starting up

- Switch on the power supply of the dbk.

Check that the system is functioning properly with the aid of a test sheet.

- Hold a test sheet inside the working range between the transmitter and receiver.

The LED must light up green. If the LED lights up red, check the installation dimensions of the dbk and the test sheet you have chosen.

- Hold a double test sheet (two sheets) inside the working range between the transmitter and receiver.

The LED must light up red.

For double-sheet detectors with missing-sheet output:

- Remove all sheets from between the transmitter and the receiver.

The LED must flash red.

Note

- The test sheet may be either a high grammage sheet of the material to be scanned or the test sheet available as an accessory from microsonic, which can be ordered under the article designation "dbk test sheet". This test sheet serves as threshold material at room temperature and can be used to verify correct adjustment and operation of the dbk.

model name	dbk-5/CDD/O/M30 E+S	dbk-5/CEE/O/M30 E+S	dbk-5/BDD/O/M30 E+S
transmitter-receiver spacing	50 mm ±3 mm	50 mm ±3 mm	50 mm ±3 mm
transmitter-receiver blind zone	7 mm in front of both transmitter and receiver	7 mm in front of both transmitter and receiver	7 mm in front of both transmitter and receiver
permissible angular deviation	± 45° from the perpendicular to the sheet	± 45° from the perpendicular to the sheet	± 45° from the perpendicular to the sheet
ultrasonic frequency	200 kHz	200 kHz	200 kHz
resolution	2 sheets not stuck together across entire surface	2 sheets not stuck together across entire surface	2 sheets not stuck together across entire surface
working range	Papers with weights from 120 g/m ² , metal-laminated sheets, corrugated card, sheet metals up to 2mm thick, PCB boards	Papers with weights from 120 g/m ² , metal-laminated sheets, corrugated card, sheet metals up to 2mm thick, PCB board	Papers with weights from 120 g/m ² , metal-laminated sheets, corrugated card, sheet metals up to 2mm thick, PCB board
operating voltage U _B	20 V bis 30 V DC	20 V bis 30 V DC	20 V bis 30 V DC
residual ripple	± 10 %	± 10 %	± 10 %
no-load current consumption	≤ 45 mA	≤ 45 mA	≤ 45 mA
type of connection	5-core cable, 2,000 mm long	5-core cable, 2,000 mm long	5-core cable, 2,000 mm long
signal cable	On receiver: 1,200 mm On transmitter: 1,000 mm, With 2-pin plug-in connector, IP 20	On receiver: 1,200 mm On transmitter: 1,000 mm, With 2-pin plug-in connector, IP 20	On receiver: 1,200 mm On transmitter: 1,000 mm, With 2-pin plug-in connector, IP 20
terminal assignment			
(brown) Pin 1	+U _B	+U _B	+U _B
(blue) Pin 3	-U _B (0 V)	-U _B (0 V)	-U _B (0 V)
(white) Pin 2	Missing sheet	Missing sheet	Missing sheet
(black) Pin 4	Double sheet	Double sheet	Double sheet
(grey) Pin 5	Control input	Control input	Control input
controls	None required	None required	None required
programmable	None required	None required	None required
double-sheet output	npn, +U _B -2 V, I _{max} = 500 mA, short-circuit-proof, NC contact	npn, -U _B +2 V, I _{max} = 500 mA, short-circuit-proof, NC contact	npn, +U _B -2 V, I _{max} = 500 mA, short-circuit-proof, NC contact
missing-sheet output	npn, +U _B -2 V, I _{max} = 500 mA, short-circuit-proof, NC contact	npn, -U _B +2 V, I _{max} = 500 mA, short-circuit-proof, NC contact	npn, +U _B -2 V, I _{max} = 500 mA, short-circuit-proof, NC contact
response time, Trigger-Mode	-	-	0.6 ms
response time, Free-Run-Mode	5.5 ms bzw. 15.5 ms	5.5 ms bzw. 15.5 ms	-
tripping delay, Trigger-Mode	-	-	State frozen until next edge
tripping delay, Free-Run-Mode	25 ms	25 ms	-
indicator	Green: stand-by Red: double sheet Flashing red: missing sheet	Green: stand-by Red: double sheet Flashing red: missing sheet	Green: stand-by Red: double sheet Flashing red: missing sheet
U _E at control input	Response time 15.5 ms: U _E > 9 V DC Response time 5.5 ms: U _E < 5 V DC or control input open	Response time 15.5 ms: U _E > 9 V DC Response time 5.5 ms: U _E < 5 V DC or control input open	dbk activated for one scan: edge change
description of control input	Free run mode only The dbk-5 scans continuously. If the control inputs remains open circuited or if it is applied to -U _B , the response time is 5.5 ms. If the control input is applied to +U _B , the response time is 15.5 ms.	Free run mode only The dbk-5 scans continuously. If the control inputs remains open circuited or if it is applied to -U _B , the response time is 5.5 ms. If the control input is applied to +U _B , the response time is 15.5 ms.	Trigger mode only One scan is performed with a rising edge at the control input (edge change -U _B to +U _B). After the response time of 600µs, both outputs are set in accordance with the result of the scan.
housing	Nickel-plated brass sleeve Plastic parts: PBT Cable: PVC sheath Ultrasonic transducer: polyurethane foam, epoxy resin with glass content	Nickel-plated brass sleeve Plastic parts: PBT Cable: PVC sheath Ultrasonic transducer: polyurethane foam, epoxy resin with glass content	Nickel-plated brass sleeve Plastic parts: PBT Cable: PVC sheath Ultrasonic transducer: polyurethane foam, epoxy resin with glass content
max. tightening torque of nuts	15 Nm	15 Nm	15 Nm
degree of protection per EN 60 529	IP 65	IP 65	IP 65
operating temperature	+5°C bis +60°C	+5°C bis +60°C	+5°C bis +60°C
storage temperature	-40°C bis +85°C	-40°C bis +85°C	-40°C bis +85°C
weight	380 g	380 g	380 g
standard conformed with	EN 60947-5-2	EN 60947-5-2	EN 60947-5-2