

Product Description

The zws sensor offers a non-contact measurement of the distance to an object which must be positioned within the sensor's detection zone. The switching output is set in dependence of the adjusted switching distance. Due to the short response time and the high switching frequency these zws sensors are applicable to the detection of quick processes. For the zws-7, the faster variant, please see the notes for installation and operation.



Operation Manual

Ultrasonic proximity switch with one switching output

zws-7/CD/QS zws-7/CE/QS
zws-15/CD/5ms.a zws-15/CE/5ms.a

Via the push-button, the detect distance and operating mode can be adjusted (teach-in, see Diagram 1). Two LEDs indicate operation and the state of the switching output.

Safety Notes

- Read the operating instructions prior to start-up.
- Connection, installation and adjustment works may only be carried out by expert personnel.
- No safety component in accordance with the EU Machine Directive.

Use for intended purpose only
pico+ ultrasonic sensors are used for non-contact detection of objects.

Installation

- ➔ Mount the sensor at the installation site with the aid of the enclosed mounting plate (see Fig. 1). Maximum torque of attachment screw: 0,5 Nm
- ➔ Connect a connection cable to the M8 device plug.
- ➔ Avoid mechanical load on the connector.

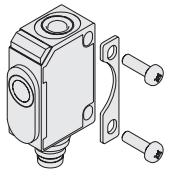

Fig. 1: Attachment with mounting plate

Start-Up

- ➔ Connect the power supply.
- ➔ Carry out the adjustment in accordance with Diagram 1.

Factory Setting

- zws-sensors are delivered with the following settings:
- Operation with one switching point
 - Switching output on NOC
 - Switching point at operating range



		colour
1	+U _B	brown
3	-U _B	blue
4	D	black
2	sync	white

Fig. 2: Pin assignment with view onto sensor plug and colour coding of the microsonic connection cable

Operating modes

Three operating modes are available for the switching output:

- **Operation with one switching point**
The switching output is set if the object falls below the set switching point.
- **Window mode**
The switching output is set if the object is within the set window margins.

- **Two-way reflective barrier**
The switching output is set if there is no object between sensor and reflector.

Checking operation mode

➔ In normal operating mode shortly press the push-button. The green LED stops shining for one second, then it will show the current operating mode:

- 1x flashing = operation with one switching point
- 2x flashing = window mode
- 3x flashing = reflective barrier

After a break of 3 s the green LED shows the **output function**:

- 1x flashing = NOC
- 2x flashing = NCC

Synchronisation

You can synchronise as many sensors as you like.

➔ Apply a square-wave signal to the sync-input with pulse width t_i and repetition rate t_p (Fig. 3 and technical data).

A high level on the sync-input will disable the sensor.

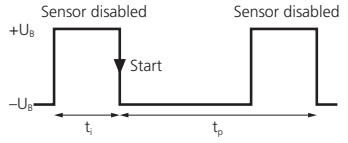
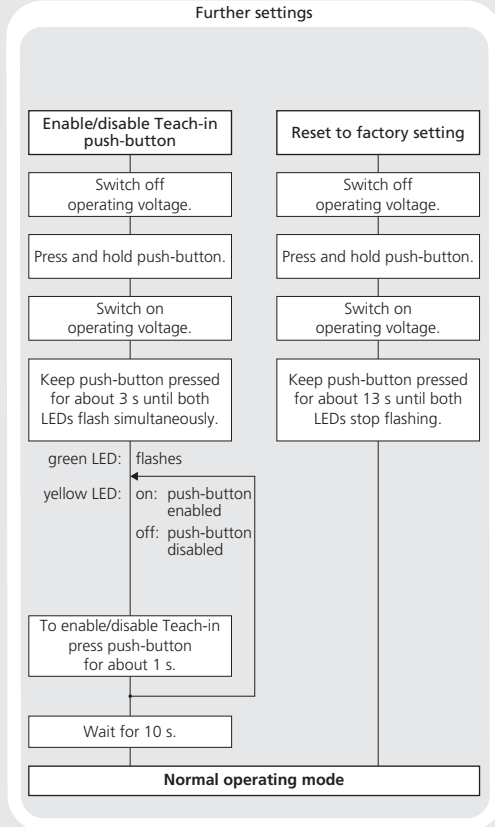
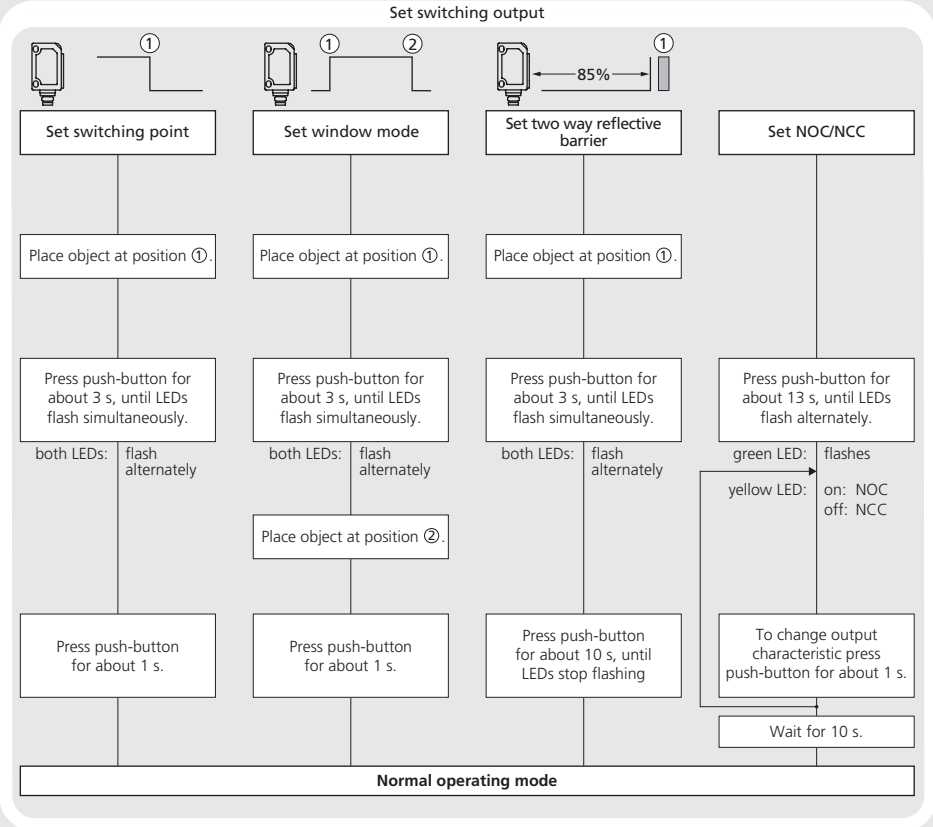

Fig. 3: External synchronisation signal

Diagram 1: Set sensor parameters via Teach-in procedure



Maintenance

microsonic sensors are maintenance-free. In case of excess caked-on dirt we recommend cleaning the white sensor surface.

Technical data

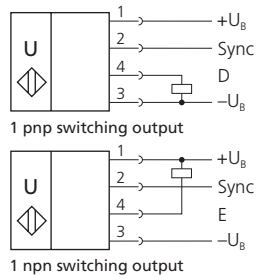

blind zone: 20 mm
operating range: 70 mm
maximum range: 100 mm
angle of beam spread: see detection zone
transducer frequency: 380 kHz
resolution: 0.2 mm
reproducibility: ±0.15 %
detection zones

for different objects:
 The dark grey areas represent the zone where it is easy to recognise the normal reflector (round bar). This indicates the typical operating range of the sensors. The light grey areas represent the zone where a very large reflector – for instance a plate – can still be recognised. The requirement here is for an optimum alignment to the sensor. It is not possible to evaluate ultrasonic reflections outside this area.

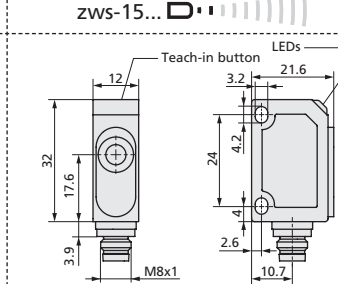
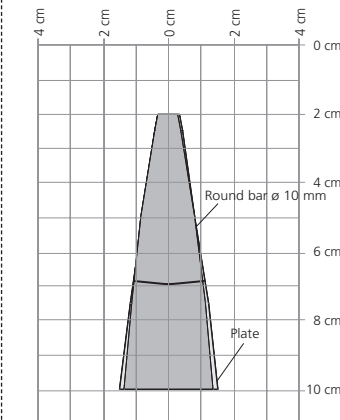

blind zone: 20 mm
operating range: 150 mm
maximum range: 250 mm
angle of beam spread: see detection zone
transducer frequency: 380 kHz
resolution: 0.2 mm
reproducibility: ±0.15 %
detection zones

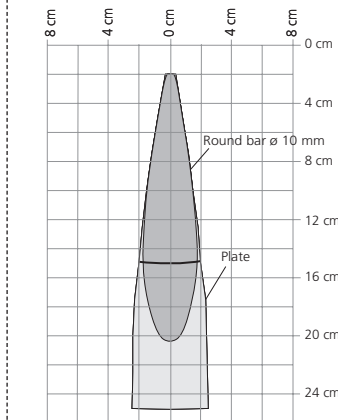

accuracy: Temperature drift 0,17 %/°C
operating voltage U_B: 20 to 30 V DC, reverse polarity protection
voltage ripple: ±10 %
no-load current consumption: <30 mA
housing: ABS
 ultrasonic transducer: polyurethane foam, epoxy resin with glass content
 IP 67

class of protection to EN 60529: EN 60947-5-2
norm conformity: EN 60947-5-2
type of connection: 4-pin M8 initiator plug
controls: Teach-in push-button
indicators: LED green (operation)
 LED yellow (state of output)

programmable synchronisation: no
external synchronisation: external
pulse width synchronisation signal t_p: >150 μs
cycle time synchronisation signal t_c: 2 ms < t_c < 1 s
operating temperature: -25 to +70 °C
storage temperature: -40 to +85 °C
weight: 10 g
switching hysteresis: 2 mm
switching frequency: 250 Hz
response time: <3 ms
switch-off delay time: <3 ms
time delay before availability: <300 ms

order no.: **zws-7/CD/QS**
switching output: pnp, U_B-2 V, I_{max} = 200 mA
 switchable NOC/NCC, short-circuit-proof

order no.: **zws-7/CE/QS**
switching output: npn, -U_B+2 V, I_{max} = 200 mA
 switchable NOC/NCC, short-circuit-proof

Notes

- The zws sensor has a blind zone, within which distance measurements are not possible.
- The zws-7 sensor has no temperature compensation.
- In the normal operating mode, an illuminated yellow LED signals the switching output is switched through.
- The sensor got to know the distance to the object at the teach-in stage. For objects that move into the sound field from the side (see Fig. 4), an 8-10 % greater distance is detected by the sensor.

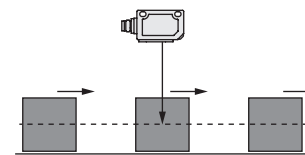

Fig. 4: Setting the switching point

- The zws-7 has a very short measurement cycle time of only 2 ms. Under unfavourable conditions this can lead to the sensor wrongly responding to echoes from existing measurements. To avoid this, there has to be an unobstructed space extending to a depth of 500 mm in front of the sensor. Only the objects to be detected are to be within the sensor's 20 to 100 mm operating area (see Fig. 5).

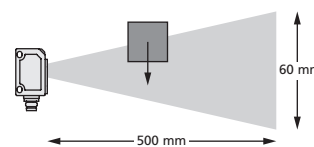

Fig. 5: Unobstructed space in front of the sensor

- With the zws-7, it is vital that the objects to be detected enter the sound fields from the sides.
- If the unobstructed 500 mm space cannot be provided or should the sensor be used in the «Two-way reflective barrier» mode, then a plane reflector at a specific distance to the sensor must be fitted (see Fig. 6). The size of the reflector and its working clearance from the sensor can be taken from the table in Fig. 7.

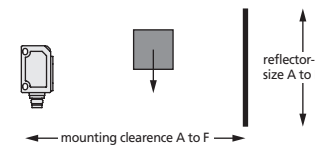

Fig. 6: Sensor/reflecter working clearance

A	366 mm	60 mm x 60 mm
B	194 mm	60 mm x 60 mm
C	137 mm	50 mm x 50 mm
D	108 mm	40 mm x 40 mm
E	91 mm	40 mm x 40 mm
F	79 mm	30 mm x 30 mm

Fig. 7: Working clearance and reflector sizes

- In the «Two-way reflective barrier» operating mode, the object has to be within the range of 0-85 % of the set distance.
- If the push-button is not pressed for 2 minutes during the teach-in setting, the settings made hitherto are deleted.
- The sensor can be reset to its factory setting, see »Further settings«, Diagram 1.