



Instruction manual Ics-Ultrasonic Sensors with one analogue output

Ics-25/IU/QP
Ics-35/IU/QP
Ics-130/IU/QP

Product description

- The Ics-sensor with one analogue output measures the distance to an object within the detection zone contactless. A signal proportional to distance is created according to the adjusted window margins of the analogue characteristic curve.
- The sensor automatically detects the load put to the analogue output and switches to current output or voltage output respectively.
- Choosing between rising and falling output characteristic is possible.
- Light emitting diodes (three-colour LEDs) indicate the operation conditions.
- The sensors can be trained using Teach-in processes.
- Using the LinkControl adapter (optional accessory) all sensor parameter settings may be made by a Windows-Software.

Important instructions for assembly and application

All employee and plant safety-relevant measures must be taken prior to assembly, start-up, or maintenance work (see operation manual for the entire plant and the operator instruction of the plant).

The sensors are not considered as safety equipment and may not be used to ensure human or machine safety!

The Ics-sensors indicate a **blind zone**, in which the distance cannot be measured. The **operating range** indicates the distance of the sensor that can be applied with normal reflectors with sufficient function reserve. When using good reflectors, such as a calm water surface, the sensor can also be used up to its **maximum range**. Objects that strongly absorb (e.g. plastic foam) or diffusely reflect sound (e.g. pebble stones) can also reduce the defined operating range.

Assembly instructions

- Assemble the sensor at the installation location.
- Plug in the connector cable to the M12 connector.

		colour
1	+U _B	brown
3	-U _B	blue
4	-	black
2	I/U	white
5	Com.	grey

Fig. 1: Pin assignment with view onto sensor plug and colour coding of the microsonic connection cable

Assembly distances

The assembly distances shown in Fig.2 for two or more sensors should not be fallen below in order to avoid mutual interference.

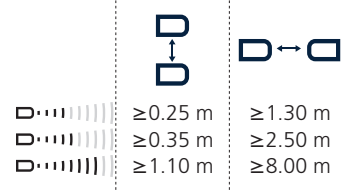

Fig. 2: Assembly distances

Start-up

Ics-sensors are delivered factory made with the following settings:

- Rising analogue characteristic
- Window margins for the analogue output set to blind zone and operating range
- Measurement range set to maximum range

Set the parameters of the sensor using the Teach-in procedure.

Operation

Ics-sensors work maintenance free. Small amounts of dirt on the surface do not influence function. Thick layers of dirt and caked-on dirt affect sensor function and therefore must be removed.

Note

- Ics-sensors have internal temperature compensation. Because the sensors heat up on their own, the temperature compensation reaches its optimum working point after approx. 30 minutes of operation.
- If an object is within the set window margins of the analogue output, then LED D1 lights up green, if the object is outside the window margins, then LED D1 lights up red.
- The load put to the analogue output is detected automatically when turning supply voltage on.
- If the signal at the Com line does not change for 20 seconds during parameter setting mode the made changes are stored and the sensor returns to normal mode operation.
- You can reset the factory settings at any time, see »Lock Teach-in & factory setting«.
- Ics-sensors optional can be programmed using the LinkControl adapter LCA-2, see »Optional setting of parameters using the LinkControl Adapter LCA-2«.

Sensor adjustment with Teach-in procedure

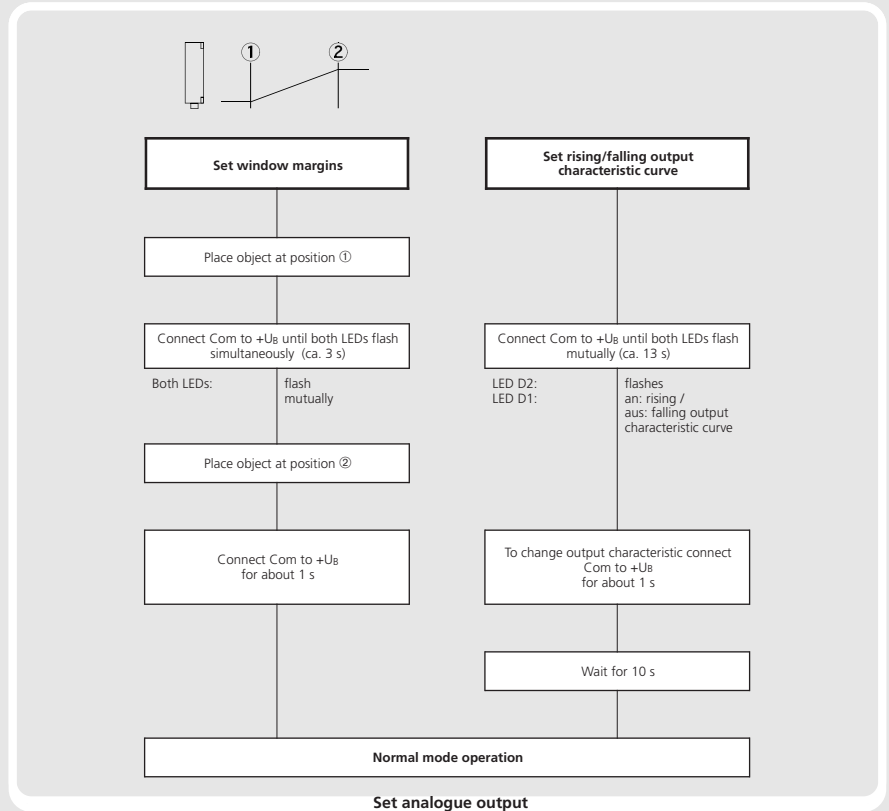

Lock Teach-in & factory setting

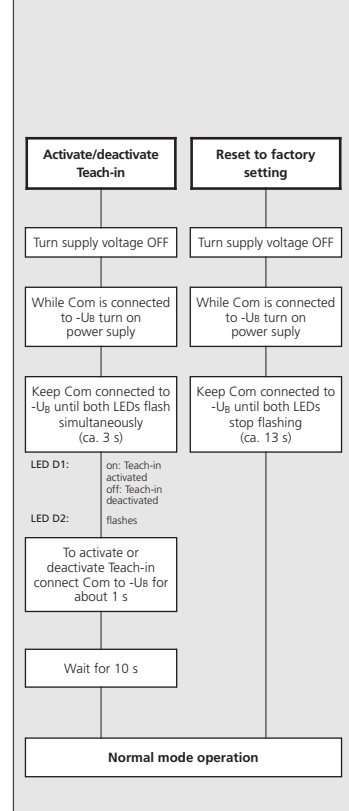

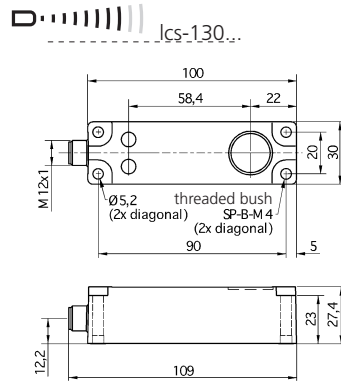
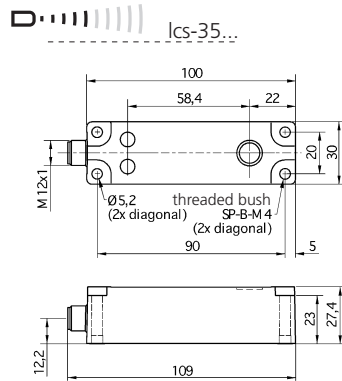
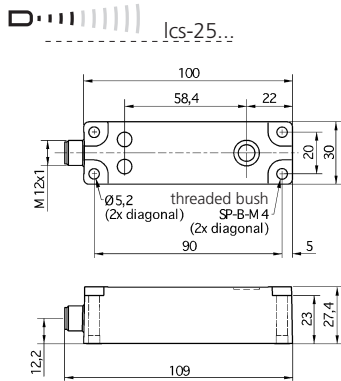

Blind zone 0 to 30 mm
Operating range 250 mm
Maximum range 350 mm
Angle of beam spread See detection zone
Transducer frequency 320 kHz
Resolution, sampling rate 0,18 mm
Reproducibility ± 0,15 %

Detection zones

for different objects:
 The dark grey areas are determined with a thin round bar (10 mm dia.) and indicate the typical operating range of a sensor. In order to obtain the light grey areas, a plate (100 x 100 mm) is introduced into the beam spread from the side. In doing so, the optimum angle between plate and sensor is always employed. This therefore indicates the maximum detection zone of the sensor. It is not possible to evaluate ultrasonic reflections outside this area.

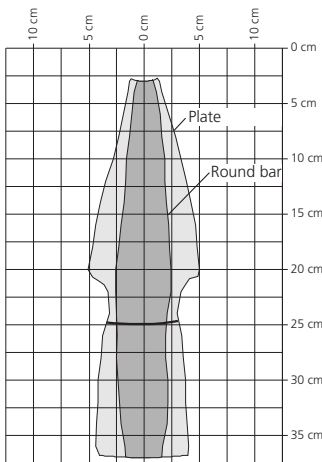

Blind zone 0 to 65 mm
Operating range 350 mm
Maximum range 600 mm
Angle of beam spread See detection zone
Transducer frequency 400 kHz
Resolution, sampling rate 0,18 mm
Reproducibility ± 0,15 %

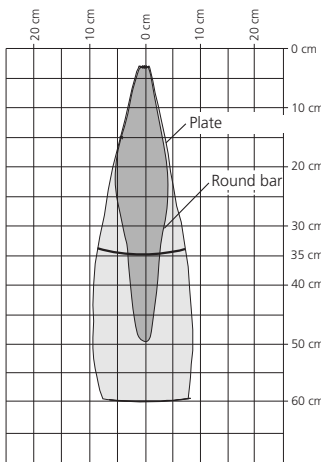

Blind zone 0 to 200 mm
Operating range 1.300 mm
Maximum range 2.000 mm
Angle of beam spread See detection zone
Transducer frequency 200 kHz
Resolution, sampling rate 0,18 mm
Reproducibility ± 0,15 %

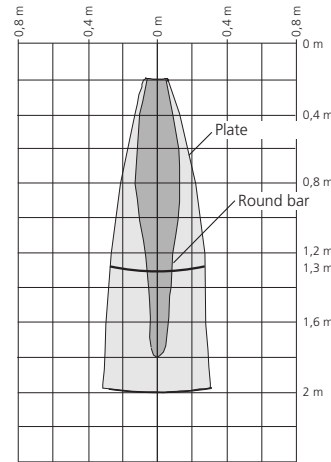

Accuracy Temperature drift internal compensated, ≤ 2%, may be deactivated ¹⁾ (0,17%/K without compensation 9 V to 30 V DC, reverse polarity protection

Operating voltage U_B

Voltage ripple ± 10 %

No-load current consumption < 60 mA

Housing PBT

ultrasonic transducer: polyurethane foam, epoxy resin with glass content IP 65

Class of protection to EN 60 529 IP 65

Norm conformity EN 60947-5-2

Type of connection 5-pin M12 initiator plug

Indicators 2 three-colour LEDs

Programmable Yes, with LCA-2 & LinkControl

Operating temperature -25°C to +70°C

Storage temperature -40°C to +85°C

Weight 120 g

Response time ¹⁾ 50 ms

Time delay before availability < 300 ms

Order No. lcs-25/IU/QP

Current output 4 – 20 mA R_L ≤ 100 Ω at 9 V ≤ U_B ≤ 20 V;
R_L ≤ 500 Ω at U_B ≥ 20 V
Rising/falling output characteristic

Voltage output 0 – 10 V R_L ≥ 100 kΩ at U_B ≥ 15 V, short-circuit-proof
Rising/falling output characteristic

Accuracy Temperature drift internal compensated, ≤ 2%, may be deactivated ¹⁾ (0,17%/K without compensation 9 V to 30 V DC, reverse polarity protection

Operating voltage U_B

Voltage ripple ± 10 %

No-load current consumption < 60 mA

Housing PBT

ultrasonic transducer: polyurethane foam, epoxy resin with glass content IP 65

Class of protection to EN 60 529 IP 65

Norm conformity EN 60947-5-2

Type of connection 5-pin M12 initiator plug

Indicators 2 three-colour LEDs

Programmable Yes, with LCA-2 & LinkControl

Operating temperature -25°C to +70°C

Storage temperature -40°C to +85°C

Weight 120 g

Response time ¹⁾ 70 ms

Time delay before availability < 300 ms

Order No. lcs-35/IU/QP

Current output 4 – 20 mA R_L ≤ 100 Ω at 9 V ≤ U_B ≤ 20 V;
R_L ≤ 500 Ω at U_B ≥ 20 V
Rising/falling output characteristic

Voltage output 0 – 10 V R_L ≥ 100 kΩ at U_B ≥ 15 V, short-circuit-proof
Rising/falling output characteristic

Accuracy Temperature drift internal compensated, ≤ 2%, may be deactivated ¹⁾ (0,17%/K without compensation 9 V to 30 V DC, reverse polarity protection

Operating voltage U_B

Voltage ripple ± 10 %

No-load current consumption < 60 mA

Housing PBT

ultrasonic transducer: polyurethane foam, epoxy resin with glass content IP 65

Class of protection to EN 60 529 IP 65

Norm conformity EN 60947-5-2

Type of connection 5-pin M12 initiator plug

Indicators 2 three-colour LEDs

Programmable Yes, with LCA-2 & LinkControl

Operating temperature -25°C to +70°C

Storage temperature -40°C to +85°C

Weight 120 g

Response time ¹⁾ 110 ms

Time delay before availability < 300 ms

Order No. lcs-130/IU/QP

Current output 4 – 20 mA R_L ≤ 100 Ω at 9 V ≤ U_B ≤ 20 V;
R_L ≤ 500 Ω at U_B ≥ 20 V
Rising/falling output characteristic

Voltage output 0 – 10 V R_L ≥ 100 kΩ at U_B ≥ 15 V, short-circuit-proof
Rising/falling output characteristic

1) Can be programmed with LinkControl

Offline programming

- Load Sensor parameters in the LinkControl Adapter LCA-2
- Change parameters and additional functions as described here
- Write changed parameters back into the lcs- sensor

Please refer to the quick reference guide on the LCA-2.

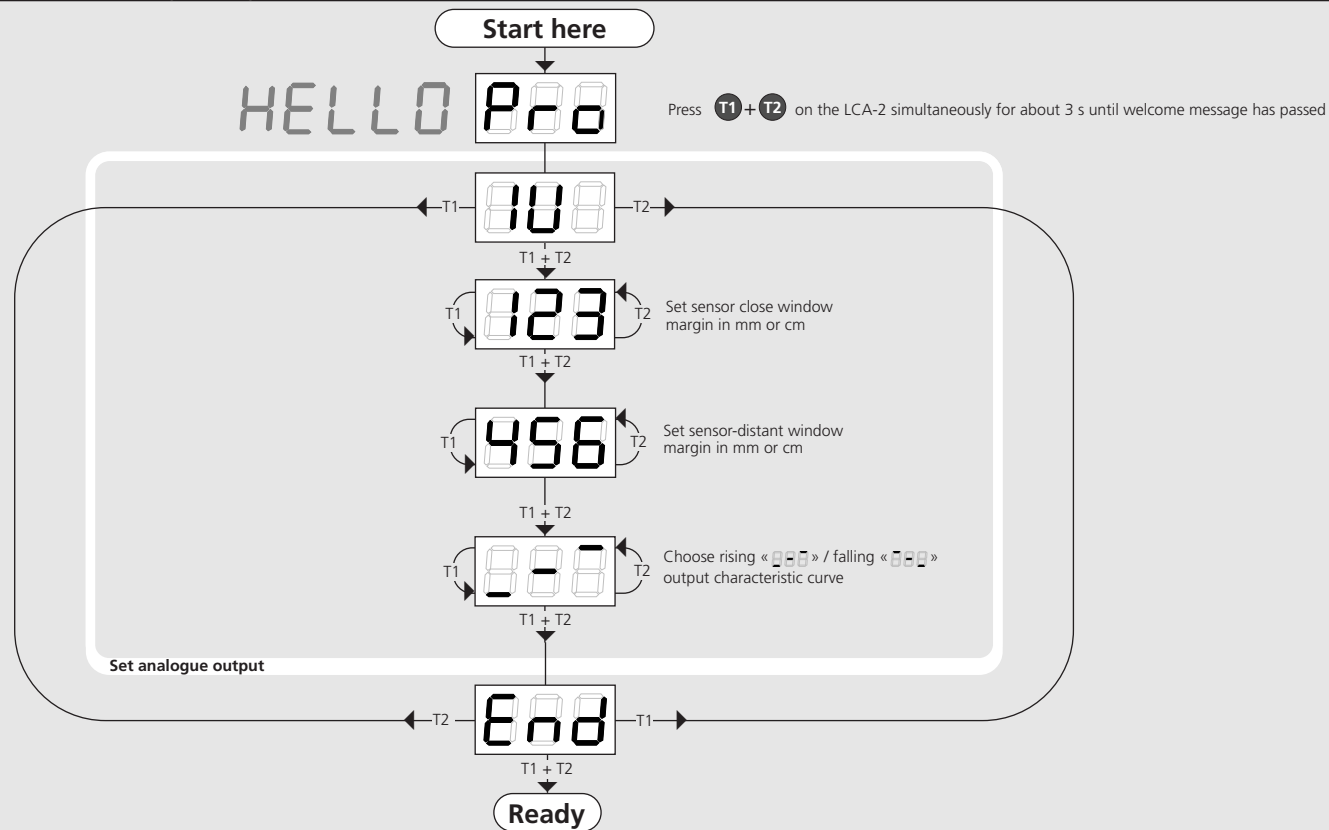

Setting of additional functions in the LCA-2

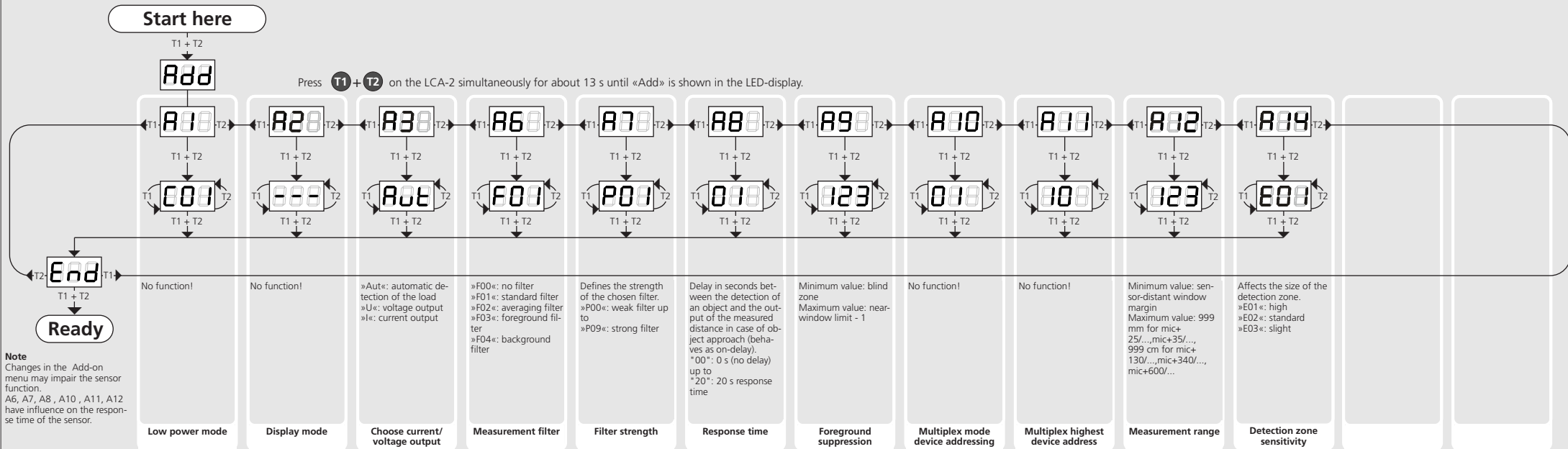

Note
Changes in the Add-on menu may impair the sensor function.
A6, A7, A8, A10, A11, A12 have influence on the response time of the sensor.