



## Operating manual crm+ Ultrasonic Sensors with two switched outputs

- crm+25/DD/TC/E
- crm+35/DD/TC/E
- crm+130/DD/TC/E
- crm+340/DD/TC/E
- crm+600/DD/TC/E

- Product description**
- The crm+ sensor with two switched outputs measures the distance to an object within the detection zone contactless. Depending on the adjusted detect distance the switched outputs are set.
  - The ultrasonic transducer surface of the crm+ sensors is laminated with a PEEK film. This composition ensures a high resistance against many aggressive substances.
  - All settings are done with two push-buttons and a three-digit LED-display (TouchControl).
  - Light emitting diodes (three-colour LEDs) indicate the switching status.
  - The output functions are changeable from NOC to NCC.
  - The sensors are adjustable manually using the numerical LED-display or may be trained using Teach-in processes.
  - Useful additional functions are set in the Add-on-menu.
  - Using the LinkControl adapter (optional accessory) all TouchControl and additional sensor parameter settings may be made by a Windows-Software.

- Safety Notes**
- Read the operating instructions prior to start-up.
  - Connection, installation and adjustment works may only be carried out by expert personnel.
  - No safety component in accordance with the EU Machine Directive.

The crm+ sensors indicate a blind zone, in which the distance cannot be measured. The operating range indicates the distance of the sensor that can be applied with normal reflectors with sufficient function reserve. When using good reflectors, such as a calm water surface, the sensor can also be used up to its maximum range. Objects that strongly absorb (e.g. plastic foam) or diffusely reflect sound (e.g. pebble stones) can also reduce the defined operating range.

**Synchronisation**  
If the assembly distances shown in Fig.1 for two or more sensors are exceeded the integrated synchronisation should be used. Connect Sync/Com-channels (pin 5 at the units receptable) of all sensors (10 maximum).

	≥0.35 m		≥2.50 m
	≥0.40 m		≥2.50 m
	≥1.10 m		≥8.00 m
	≥2.00 m		≥18.00 m
	≥4.00 m		≥30.00 m

Fig. 1: Assembly distances, indicating synchronisation/multiplex

**Multiplex mode**  
The Add-on-menu allows to assign an individual address »01« to »10« to each sensor connected via the Sync/Com-channel (Pin5). The sensors perform the ultrasonic measurement sequentially from low to high address. Therefore any influence between the sensors is rejected. The address »00« is reserved to synchronisation mode and deactivates the multiplex mode. (To use synchronised mode all sensors must be set to address »00«.)

- Assembly instructions**
- Assemble the sensor at the installation location.
  - Plug in the connector cable to the M 12 connector.

	+U <sub>B</sub>	brown
	-U <sub>B</sub>	blue
	D2	black
	D1	white
	Sync/Com.	grey

Fig. 2: Pin assignment with view onto sensor plug and colour coding of the microsonic connection cable

- Start-up**  
crm+ sensors are delivered factory made with the following settings:
- Switched output on NOC
  - Detecting distance at operating range and half operating range
  - Measurement range set to maximum range

Set the parameters of the sensor manually or use the Teach-in procedure to adjust the detect points.

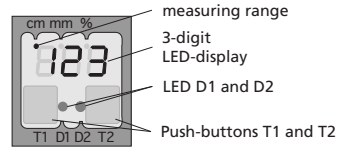

Fig. 3: TouchControl

**Operation**  
crm+ sensors work maintenance free. Small amounts of dirt on the surface do not influence function. Thick layers of dirt and caked-on dirt affect sensor function and therefore must be removed.

- Note**
- As a result of the design the assembly of PEEK film and PTFE joint ring is not gas-proof.
  - The chemical resistance has to be tested experimentally if necessary.
  - crm+ sensors have internal temperature compensation. Because the sensors heat up on their own, the temperature compensation reaches its optimum working point after approx. 30 minutes of operation.
  - During normal mode operation, a yellow LED D2 signals that the switched output has connected.
  - During normal mode operation, the measured distance value is displayed on the LED-indicator in mm (up to 999 mm) or cm (from 100 cm). Scale switches automatically and is indicated by a point on top of the digits.
  - During Teach-in mode, the hysteresis loops are set back to factory settings.
  - If no objects are placed within the detection zone the LED-indicator shows »- -«.
  - If no push-buttons are pressed for 20 seconds during parameter setting mode the sensor returns to normal mode operation.
  - You can lock the key pad to provide inputs, see »Key lock and factory setting«.
  - You can reset the factory settings at any time, see »Key lock and factory setting«.

**Show parameters**  
Tapping push-button T1 shortly during normal mode operation shows »PA« on the LED-display. Each time you tap push-button T1 the actual settings of the switched output are shown.

## Set sensor parameters alternatively numerically using LED-display...

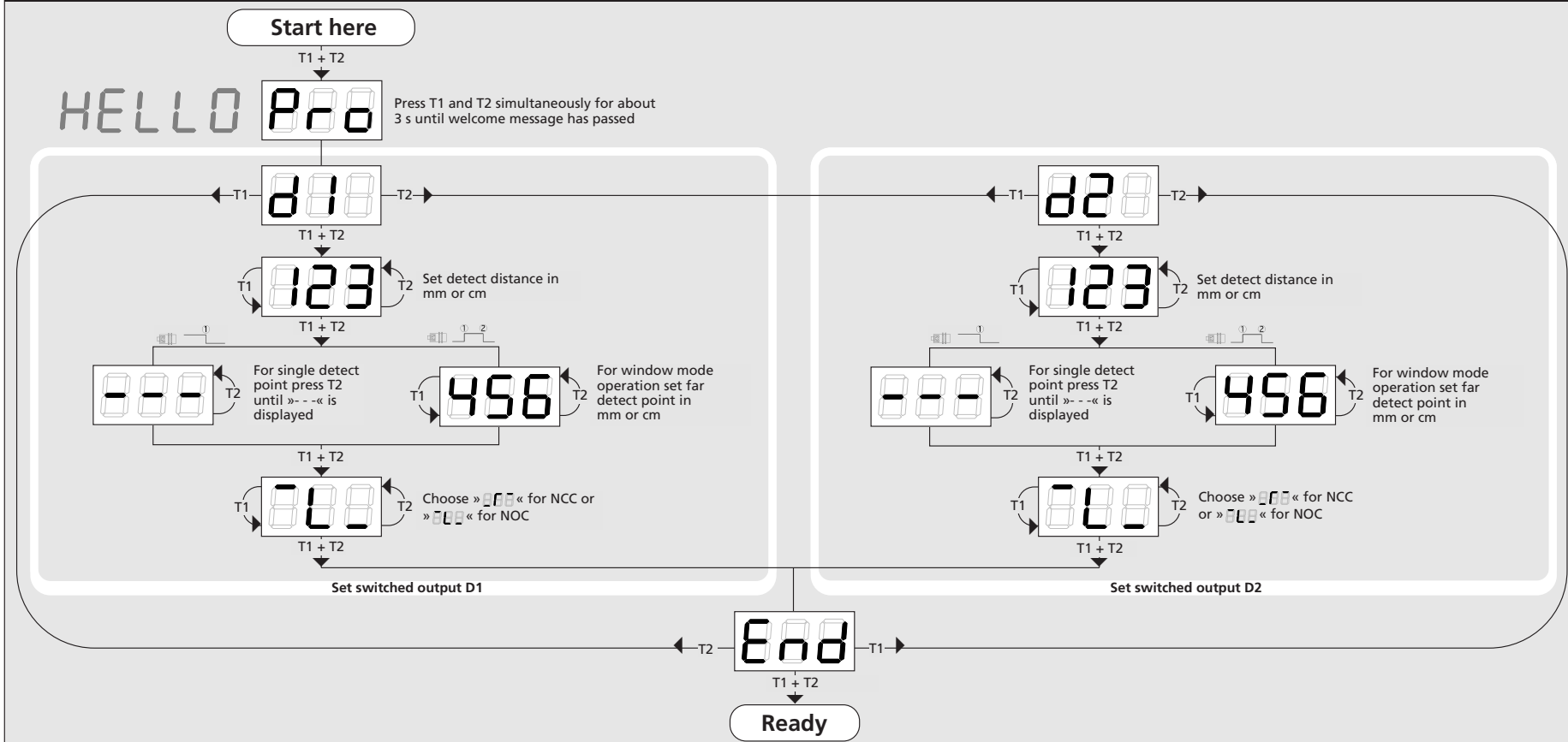

# ...or with the Teach-in procedure

**Adjust detect point D1**  
Place object at position ①  
Press T1 until »d« is shown  
Current measuring value: 123

**Adjust window mode D1**  
Place object at position ①  
Press T1 until »d« is shown  
Current measuring value: 123  
Place object at position ②  
Current measuring value: 456

**Adjust two-way reflectiv barrier D1**  
Place reflector at position ①  
Press T1 until »d« is shown  
Current measuring value: 123

**Set NOC/NCC D1**  
Press T1 until countdown passed from »- 8 -« to »- 0 -« and NOC or NCC symbol is displayed  
Symbol NOC or NCC: 000  
Press T1 until »End« is shown  
To change output function press T1  
Press T1 and T2 simultaneously until »End« is displayed  
Symbol NOC or NCC: 000

Normal mode operation

Teach-in switched output D1

**Adjust detect point D2**  
Place object at position ①  
Press T2 until »d« is shown  
Current measuring value: 123

**Adjust window mode D2**  
Place object at position ①  
Press T2 until »d« is shown  
Current measuring value: 123  
Place object at position ②  
Current measuring value: 456

**Adjust two-way reflectiv barrier D2**  
Place reflector at position ①  
Press T2 until »d« is shown  
Current measuring value: 123

**Set NOC/NCC D2**  
Press T2 until countdown passed from »- 8 -« to »- 0 -« and NOC or NCC symbol is displayed  
Symbol NOC or NCC: 000  
Press T2 until »End« is shown  
To change output function press T2  
Press T1 and T2 simultaneously until »End« is displayed  
Symbol NOC or NCC: 000

Normal mode operation

Teach-in switched output D2

# Key lock and factory setting

**Activate/deactivate TouchControl**  
Turn supply voltage OFF  
While pressing T1 turn supply voltage ON until »on« or »off« is displayed  
To activate or deactivate press T1  
»on« or »off«

**Reset to factory setting**  
Turn supply voltage OFF  
While pressing T1 turn supply voltage ON for ca. 15 s until »rESET« has past through the display  
To activate or deactivate press T1  
»on« or »off«

Normal mode operation

# Usefull additional functions in Add-on menu (for experienced users only, settings not required for standard applications)

**Start here**  
Press T1 and T2 simultaneously for about 13 s until »Add« is shown in the LED-display

HELLO Pro **Add-on**

**Ready**

<p>»C01«: Display bright »C02«: Display dimmed »C03«: Display off</p> <p><b>Low power mode</b></p>	<p>Minimum value: »001« Maximum value: difference between maximum range and detect point - 1 During window mode operation hysteresis influences both detect points.</p> <p><b>Hysteresis switched output D1</b></p>	<p>Minimum value: »001« Maximum value: difference between maximum range and detect point - 1 During window mode operation hysteresis influences both detect points.</p> <p><b>Hysteresis switched output D2</b></p>	<p>»F00«: no filter »F01«: standard filter »F02«: averaging filter »F03«: foreground filter »F04«: background filter</p> <p><b>Measurement filter</b></p>	<p>Defines the strength of the chosen filter. »P00«: weak filter up to »P09«: strong filter</p> <p><b>Filter strength</b></p>	<p>Delay in seconds between the detection of an object and the output of the measured distance in case of object approach (behaves as on-delay). "00": 0 s (no delay) up to "20": 20 s response time</p> <p><b>Response time</b></p>	<p>Minimum value: blind zone Maximum value: nearwindow limit - 1</p> <p><b>Foreground suppression</b></p>	<p>»00«: synchronisation »01« to »10«: sensor address for multiplex mode »0F«: synchronisation deactivated</p> <p><b>Multiplex mode device addressing</b></p>	<p>To optimize multiplex speed the highest sensor address may be set. Setting range »01« to »10«</p> <p><b>Multiplex mode highest address</b></p>	<p>Minimum value: sensor-distant window margin Maximum value: 999 mm for crm+25/... and crm+35/... and 900 mm for all other types</p> <p><b>Measurement range</b></p>	<p>Put plane reflector vertically disposed in front of sensor: in an exact distance of 250 mm for crm+25/... and crm+35/... and 900 mm for all other types. Adjust display to 250 mm or 900 mm. Confirm calibration with T1 + T2.</p> <p><b>Calibration display</b></p>	<p>Affects the size of the detection zone. »E01«: high »E02«: standard »E03«: slight</p> <p><b>Detection zone sensitivity</b></p>
--	---	---	---	---	--	---	---	---	---	---	---

**Note**  
Changes in the Add-on menu may impair the sensor function.  
A6, A7, A8, A10, A11, A12 have influence on the response time of the sensor.

# Technical data

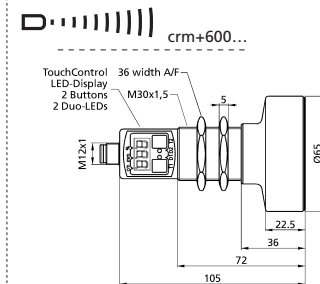
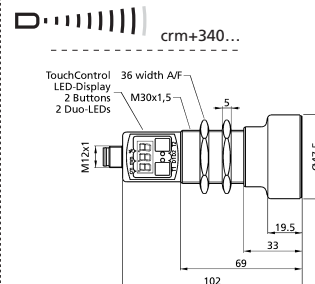
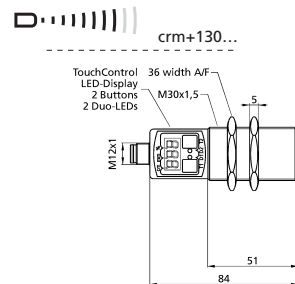
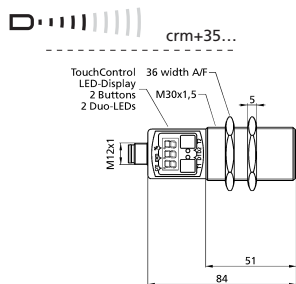
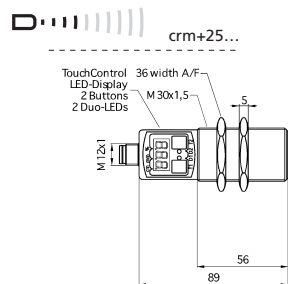
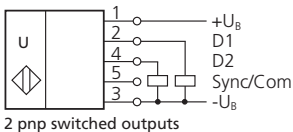

<b>Blind zone</b>	0 to 30 mm	0 to 85 mm	0 to 200 mm	0 to 350 mm	0 to 600 mm
<b>Operating range</b>	250 mm	350 mm	1.300 mm	3.400 mm	6.000 mm
<b>Maximum range</b>	350 mm	600 mm	2.000 mm	5.000 mm	8.000 mm
<b>Angle of beam spread</b>	Please see detection zone				
<b>Transducer frequency</b>	ca. 320 kHz	360 kHz	200 kHz	120 kHz	80 kHz
<b>Resolution, sampling rate</b>	0.025 mm	0.025 mm	0.18 mm	0.18 mm	0.18 mm
<b>Reproducibility</b>	± 0.15 %	± 0.15 %	± 0.15 %	± 0.15 %	± 0.15 %
<b>Accuracy</b>	± 1 % (Temperature drift internal compensated. may be deactivated <sup>1)</sup> 0.17%/K without compensation)				

**Detection zones for different objects:**  
The dark grey areas are determined with a thin round bar (10 or 27 mm dia.) and indicate the typical operating range of a sensor. In order to obtain the light grey areas, a plate (500 x 500 mm) is introduced into the beam spread from the side. In doing so, the optimum angle between plate and sensor is always employed. This therefore indicates the maximum detection zone of the sensor. It is not possible to evaluate ultrasonic reflections outside this area.

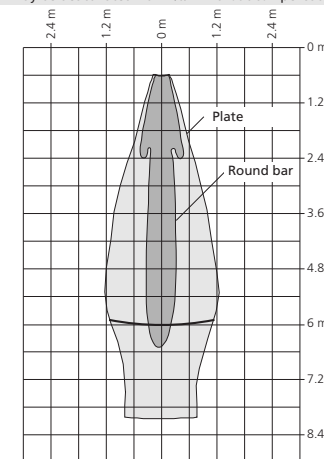
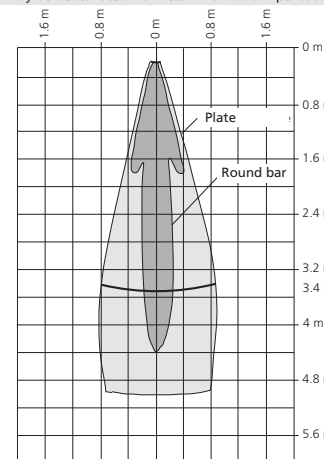
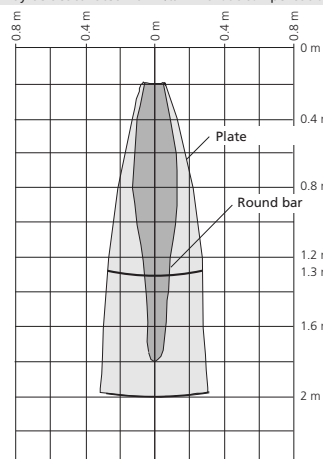
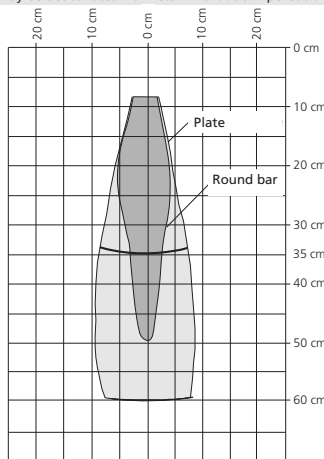
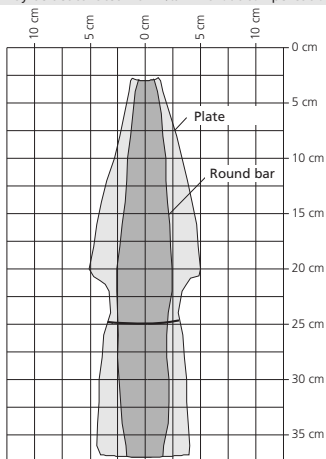

<b>Operating voltage U<sub>B</sub></b>	9 V to 30 V DC, reverse polarity protection	9 V to 30 V DC, reverse polarity protection	9 V to 30 V DC, reverse polarity protection	9 V to 30 V DC, reverse polarity protection	9 V to 30 V DC, reverse polarity protection
<b>Voltage ripple</b>	±10 %	±10 %	±10 %	±10 %	±10 %
<b>No-load supply current</b>	≤ 80 mA	≤ 80 mA	≤ 80 mA	≤ 80 mA	≤ 80 mA
<b>Housing</b>	Stainless steel 1.4571, plastic parts: PBT, TPU; Ultrasonic transducer: PEEK film, PTFE				
<b>Class of protection to EN 60529</b>	IP 67				
<b>Norm conformity</b>	EN 60947-5-2				
<b>Type of connection</b>	5-pin initiator plug, PBT				
<b>Controls</b>	2 push-buttons (TouchControl)				
<b>Indicators</b>	3-digit LED-display, 2 three-colour LEDs				
<b>Programmable</b>	Yes, with TouchControl and LinkControl				
<b>Operating temperature</b>	-25°C bis +70°C				
<b>Storage temperature</b>	-40°C bis +85°C				
<b>Weight</b>	150 g	150 g	150 g	210 g	270 g
<b>Switching hysteresis<sup>1)</sup></b>	3 mm	5 mm	20 mm	50 mm	100 mm
<b>switching frequency<sup>1)</sup></b>	25 Hz	12 Hz	8 Hz	4 Hz	3 Hz
<b>Response time<sup>1)</sup></b>	32 ms	64 ms	92 ms	172 ms	240 ms
<b>Time delay before availability</b>	< 300 ms	< 300 ms	< 300 ms	< 380 ms	< 450 ms
<b>Order No.</b>	crm+25/DD/TC	crm+35/DD/TC	crm+130/DD/TC	crm+340/DD/TC	crm+600/DD/TC
<b>Switched output</b>	2 x pnp, U <sub>B</sub> - 2 V, I <sub>max</sub> = 2 x 200 mA switchable NOC/NCC, short-circuit-proof				

<sup>1)</sup> Can be programmed with TouchControl and LinkControl

