

Product description

The lcs+ sensor offers a non-contact measurement of the distance to an object that has to be present within the sensor's detection zone. Depending on the set window limits, a distance-proportional analogue signal is output. The window limits of the analogue output and its characteristic can be adjusted with the Teach-in procedure. One 2-colour LED indicates the state of the analogue output.

The sensor automatically detects the load put to the analogue output and switches to current output or voltage output respectively. Optionally all Teach-in and additional sensor parameter settings can be made using the LinkControl Adapter LCA-2 (optional accessory) and the LinkControl software for windows.



Operating manual

Ultrasonic sensor with one analogue output

lcs+340/IU
lcs+600/IU

Safety instructions

- Read the operating instructions prior to start-up.
- Connection, installation and adjustments may only be carried out by qualified staff.
- No safety component in accordance with the EU Machine Directive

Use for intended purpose only

lcs+ ultrasonic sensors are used for non-contact detection of objects.

Installation

- Mount the sensor at the place of fitting.
- Connect a connection cable to the M12 device plug

Start-up

- Connect the power supply.
- Carry out sensor adjustment in accordance with the diagram.

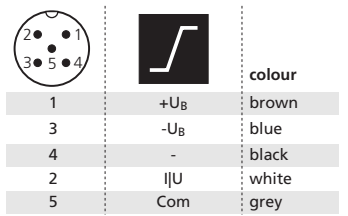

Fig. 1: Pin assignment with view onto sensor plug and colour coding of the microsonic connection cable

Factory Setting

- Rising analogue characteristic curve.

- Window limits between blind zone and operating range.

Synchronisation

If under multiple sensor operation the assembly distance falls below the values shown in Fig. 2, the internal synchronisation should be used. For this purpose interconnect each pin 5 of maximum 10 sensors to be synchronised.



Fig. 2: Assembly distances

Maintenance

microsonic sensors are maintenance-free. In case of excess caked-on dirt we recommend cleaning the white sensor surface.

Notes

- The sensors of the lcs+ family have a blind zone, within which a distance measurement is not possible.
- The lcs+ sensors are equipped with an internal temperature compensation. Due to the sensors self heating, the temperature compensation reaches its optimum working-point after approx. 30 minutes of operation.
- The load put to the analogue output is detected automatically when turning power supply on.
- If an object is within the set window margins of the analogue output, then LED D1 lights up green, if the object is outside the window margins, then LED D1 lights up red.
- If no push-buttons are pressed for 20 seconds during parameter setting mode the made changes are stored and the sensor returns to normal mode operation.
- The sensor can be reset to its factory setting (see »Sensor adjustment with Teach-in procedure«).
- Optionally all Teach-in and additional sensor parameter settings can be made using the LinkControl adapter (optional accessory) and the LinkControl software for windows.

Sensor adjustment with Teach-in procedure

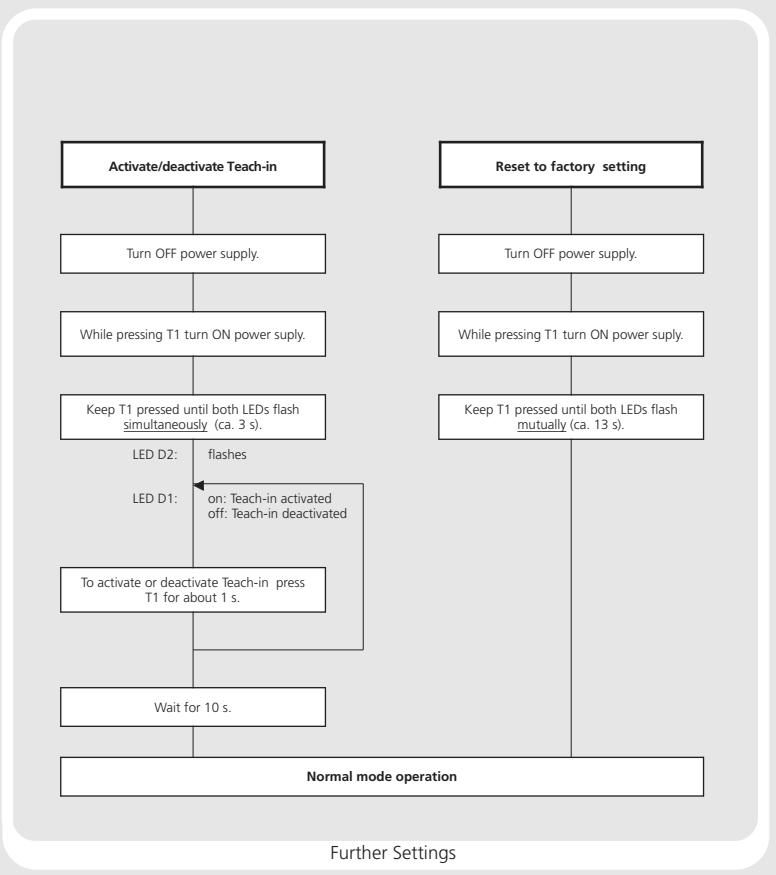
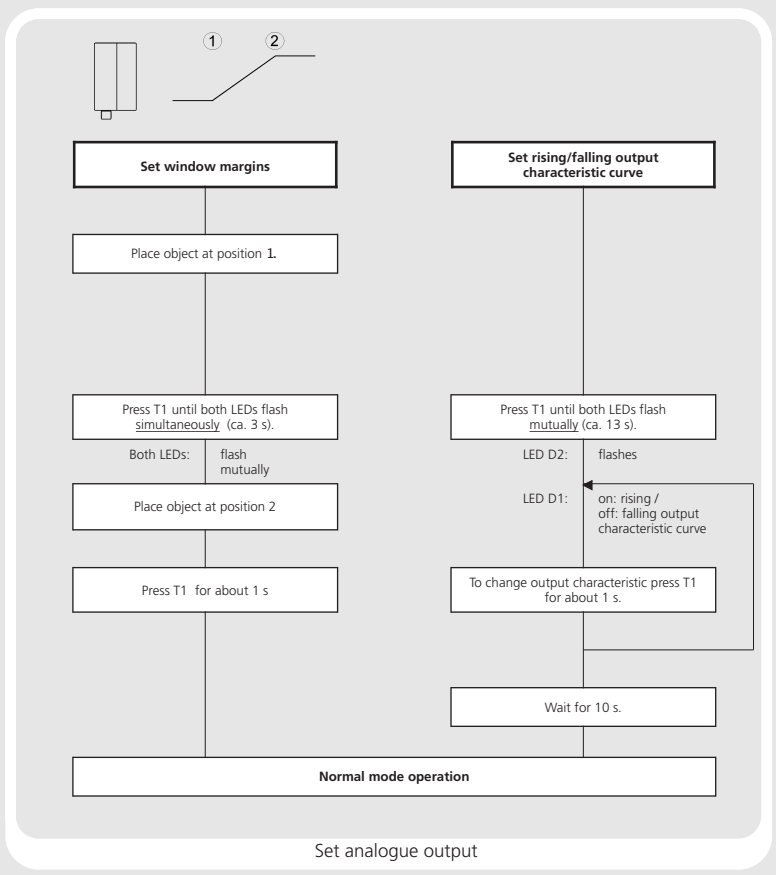

Technical data

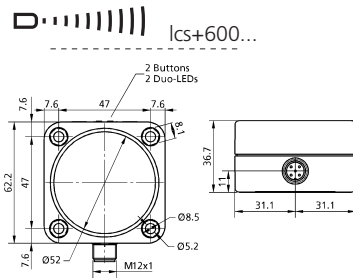
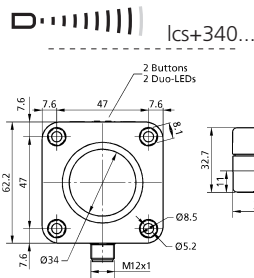
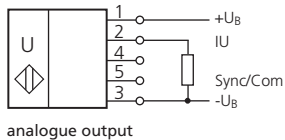

blind zone
operating range
maximum range
angle of beam spread
transducer frequency
resolution

0 to 350 mm
 3,400 mm
 5,000 mm
 see detection zone
 120 kHz
 0.18 mm to 1.5 mm, depending on the analogue window

0 to 600 mm
 6,000 mm
 8,000 mm
 see detection zone
 80 kHz
 0.18 mm to 2.4 mm, depending on the analogue window

detection zones
 for different objects:
 The dark grey areas represent the zone where it is easy to recognise the normal reflector (round bar). This indicates the typical operating range of the sensors. The light grey areas represent the zone where a very large reflector – for instance a plate – can still be recognized. The requirement here is for an optimum alignment to the sensor. It is not possible to evaluate ultrasonic reflections outside this area.

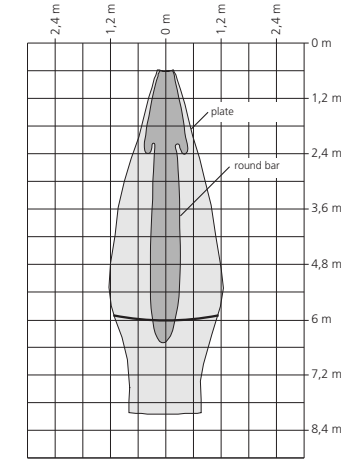
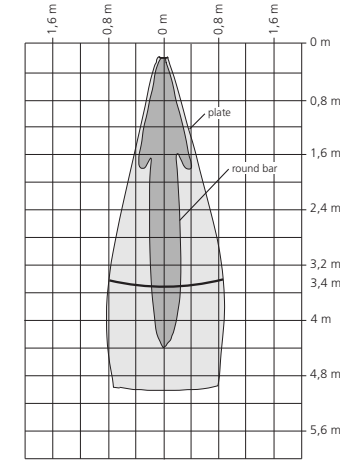

reproducibility
accuracy
operating voltage U_B
voltage ripple
no-load current consumption
housing
class of protection per EN 60 529
type of connection
controls
programmable
indicator
synchronisation
operating temperature
storage temperature
weight
response time ¹⁾
time delay before availability ¹⁾
norm conformity

± 0.15 %
 ±1 % (temperature drift internally compensated; may be deactivated, 0,17 %/K without compensation)
 9 V to 30 V DC, reverse polarity protection
 ±10 %
 ≤ 60 mA
 PBT, Polyester; ultrasonic transducer: polyurethane foam, epoxy resin with glass content IP 67
 5-pin M12 circular plug, PBT
 2 push-buttons
 • Teach-in via push-buttons
 • LCA-2 with LinkControl
 LED D1 green/red (object within/outside margins)
 internal synchronisation up to 10 sensors
 -25°C to +70°C
 -40°C to +85°C
 180 g
 172 ms
 < 450 ms
 EN 60947-5-2

± 0.15 %
 ±1 % (temperature drift internally compensated; may be deactivated, 0,17 %/K without compensation)
 9 V to 30 V DC, reverse polarity protection
 ±10 %
 ≤ 60 mA
 PBT, Polyester; ultrasonic transducer: polyurethane foam, epoxy resin with glass content IP 67
 5-pin M12 circular plug, PBT
 2 push-buttons
 • Teach-in via push-buttons
 • LCA-2 with LinkControl
 LED D1 green/red (object within/outside margins)
 internal synchronisation up to 10 sensors
 -25°C to +70°C
 -40°C to +85°C
 240 g
 240 ms
 < 450 ms
 EN 60947-5-2

order no.
current output 4 - 20 mA
voltage output 0 - 10 V

ICS+340/IU
 $R_L \leq 100 \Omega$ at $9V \leq U_B \leq 15V$;
 $R_L \leq 500 \Omega$ at $U_B \geq 15V$
 rising/falling output characteristic
 $R_L \geq 100 \text{ k}\Omega$ at $U_B \geq 15V$, short-circuit-proof
 rising/falling output characteristic

ICS+600/IU
 $R_L \leq 100 \Omega$ at $9V \leq U_B \leq 15V$;
 $R_L \leq 500 \Omega$ at $U_B \geq 15V$
 rising/falling output characteristic
 $R_L \geq 100 \text{ k}\Omega$ at $U_B \geq 15V$, short-circuit-proof
 rising/falling output characteristic

1) Can be programmed with LinkControl

