



**Product description**  
 The pms sensor has a stainless steel housing and is designed for applications with hygienic requirements. The ultrasonic transducer surface of the pms sensors is laminated with a PTFE film. The transducer itself is sealed against the housing by a joint ring made of FKM.  
 The pms sensor with D12 adapter shaft can be fitted in a mounting clip which meets hygiene standards like the sensor screw connection BF-pms/A1. The special housing design ensures that any cleaning fluids are able to run off completely, regardless of the installation situation. The pms sensor is ECOLAB and EHEDG certified. The pms sensor offers a non-contact measurement of the distance to an object present within the sensors's detection zone.

**Operating Manual**  
**Ultrasonic proximity switch with one push-pull switching output and IO-Link**

- pms-15/CF/A1
- pms-25/CF/A1
- pms-35/CF/A1
- pms-100/CF/A1

The switching output is set conditional upon the adjusted switching distance. For sensor setting, the accessory LinkControl adapter LCA-2 is recommended in combination with LinkControl software for Windows®. Alternatively, the sensor can also be set by Teach-in via pin 2 or IO-Link.

- Safety instructions**
- Read the operating manual prior to start-up.
  - Connection, installation and adjustments may only be carried out by qualified staff.
  - No safety component in accordance with the EU Machine Directive, use in the area of personal and machine protection not permitted.

**IO-Link**  
 The pms sensor is IO-Link-capable in accordance with IO-Link specification V1.1 and supports Smart Sensor Profile like Digital Measuring Sensor. The sensor can be monitored and parameterized via IO-Link.

**Use for intended purpose only**  
 pms ultrasonic sensors are used for non-contact detection of objects. The sensor must be mounted in an EHEDG-approved mounting clip, such as the sensor screw connection BF-pms/A1 for a EHEDG-compliant use.

**Installation**  
 → Assemble the sensor and its hygienic D12 sensor screw connection BF-pms/A1 or an equivalent sensor mounting clip at the installation location.

Pin	microsonic notation	IO-Link notation	IO-Link Smart Sensor Profile	colour
1	+U <sub>B</sub>	L+	SSC1	brown
3	-U <sub>B</sub>	L-		blue
4	F	Q		black
2	Com	NC		white

Fig. 1: Pin assignment with view onto sensor plug, IO-Link notation and colour coding of the microsonic connection cables

- Pull sensor cable through the sensor gland, connect it to the M8 sensor plug, see Fig. 1.
- Push the sensor with its shaft into the sensor screw connection BF-pms/A1 and align the sensor (see Fig. 4 to Fig. 6). Tighten with lock nut (maximum tightening torque 30 Nm).

**Start-up**  
 → Connect the power supply.  
 → Carry out sensor adjustment with LinkControl, IO-Link or alternatively Teach-in procedure in accordance with Diagram 1.

- Factory setting**
- Switching point operation
  - Switching output on NOC
  - Switching distance at operating range
  - Filter at F01
  - Filter strength at P00

**Operating modes**  
 Three operating modes are available for the switching output:

- **Operation with one switching point**  
 The switching output is set when the object falls below the set switching point.
- **Window mode**  
 The switching output is set when the object is inside the set window.
- **Two-way reflective barrier**  
 The switching output is set if there is no object between sensor and reflector.

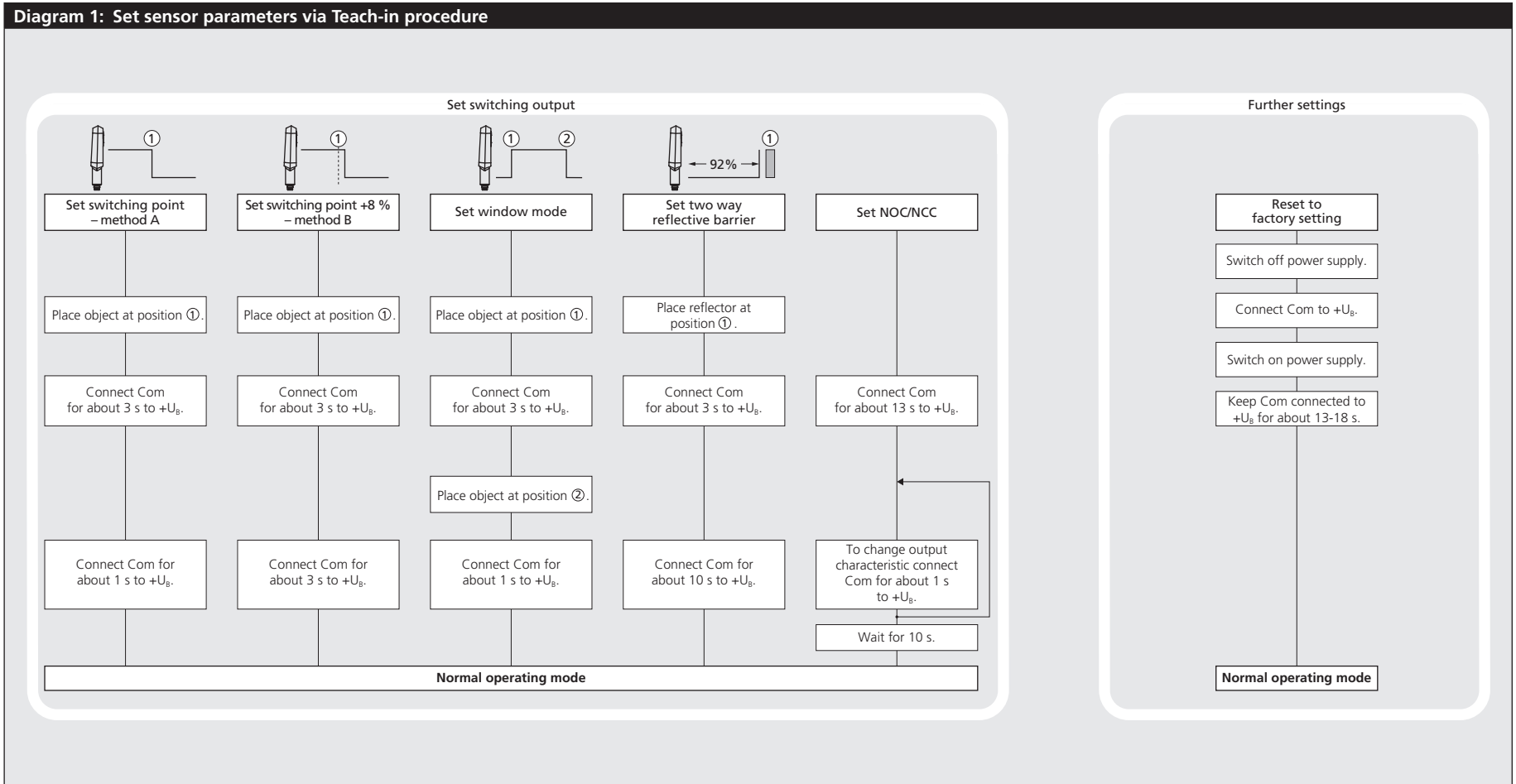

	D ↓ D	D ↔ D
pms-15...	≥0.25 m	≥1.30 m
pms-25...	≥0.35 m	≥2.50 m
pms-35...	≥0.40 m	≥2.50 m
pms-100...	≥0.70 m	≥4.00 m

Fig. 2: Assembly distances to avoid a mutual influence of the sensors

## Maintenance

microsonic sensors are maintenance-free. For cleaning in areas with hygienic requirements, access to the sensor must be guaranteed from all EHEDG. The pms sensor is ECOLAB certified. Observe the following points when cleaning:

- Use the cleaning agents listed in the ECOLAB certificate to clean the sensors (the certificate is available for download on the pms sensor page on microsonic.de).
- If other cleaning agents are used, first test whether the sensor materials (stainless steel, FKM, PTFE) are resistant to them.
- Observe the allowed maximum cleaning temperature of 85 °C.
- The use of a high-pressure cleaner is not permitted.
- Do not remove caked-on material from the sensor membrane with sharp objects.
- Do not damage the sensor membrane.

## Notes

- The sensors of the pms family have a blind zone, within which a distance measurement is not possible.
- If several pms sensors are operated in a small space, the minimum mounting for parallel or opposite arrangement of the sensors shown in figure 2 must be maintained.
- The pms sensors are equipped with an internal temperature compensation. Due to the sensors self heating, the temperature compensation reaches its optimum working-point after approx. 45 seconds of operation.
- The sensor can be reset to its factory settings (see »Further settings«, Diagram 1).
- With the two-way reflective barrier the object may be in the range of 0-92 % of the Teach-in distance.
- In the »Set switching point – method A« Teach-in procedure the actual distance to the object is taught to the sensor as the switching point. If the object moves towards the sensor (e.g. with level control) then the taught distance is the level at which the sensor has to switch the output (see Fig. 3).

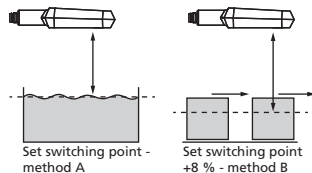

Fig. 3: Setting the switching point for different directions of movement of the object

- If the object to be scanned moves into the detection area from the side, the »Set switching point +8 % – method B« Teach-in procedure should be used. In this way the switching distance is set 8 % further than the actual measured distance to the object. This ensures a reliable switching behavior even if the height of the objects varies slightly (see Fig. 3).

## Notes on installation

- For Teach-in procedure when using the LinkControl adapter (optional accessory) the additional adapter 5G/M12-4G/M12/M8 is needed.
- If the sensor is cleaned wet, all surfaces must be inclined at least 3° from the horizontal alignment so that the cleaning agents can run off completely (see Fig. 4 to Fig. 6). There is a risk that condensate or dripping water might drip from the sensor and mounting brackets into the product area.

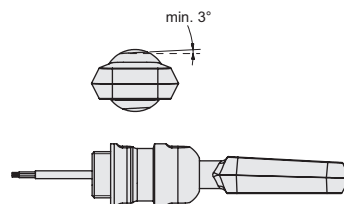

Fig. 4: pms sensor D12-adapter shaft with sensor screw connection BF-pms/A1, all surfaces must be inclined at least 3°

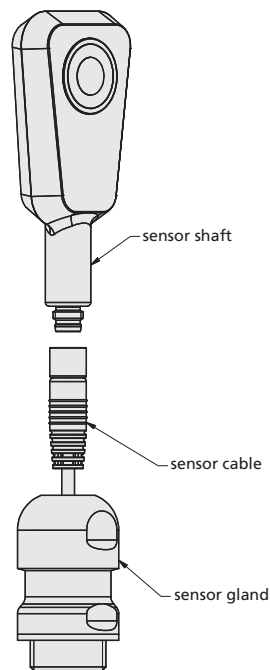

Fig. 5: Mounting of pms sensor with sensor screw connection BF-pms/A1

- The D12 adapter shaft of the pms sensor has to stick out  $7 \pm 1$  mm from the screw connection for hygienic mounting (see Fig. 5 and Fig. 6).
- The sealing ring has to fill space between D12 sensor shaft and cap nut. Sealing ring should not be pressed out excessively from the shaft gland.

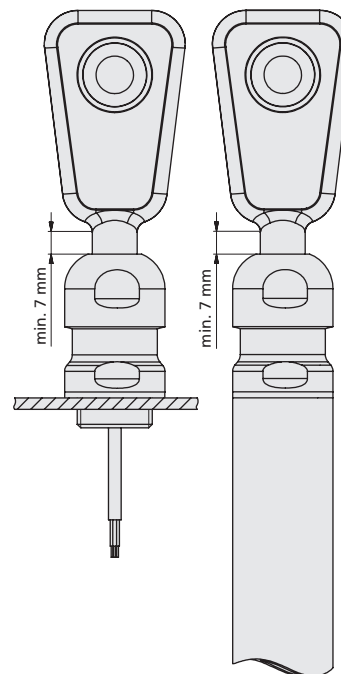

Fig. 6: pms sensor D12 adapter shaft with sensor screw connection BF-pms/A1 mounted to machine part or to stainless steel tube D26.8 with internal thread M20x1.5

## Mounting accessory

- D12 sensor screw connection BF-pms/A1

## Accessory for programming

- LinkControl adapter LCA-2
- Adapter 5G/M12-4G/M12/M8

## IODD File

The latest IODD and further information about start-up of pms sensors with IO-Link, you will find online at [www.microsonic.de/en/pms](http://www.microsonic.de/en/pms).

Technical data

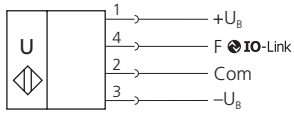

pms-15...

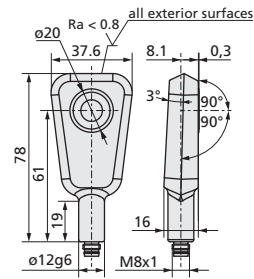

pms-25...

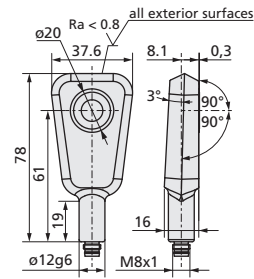

pms-35...

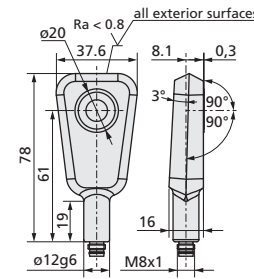

pms-100...

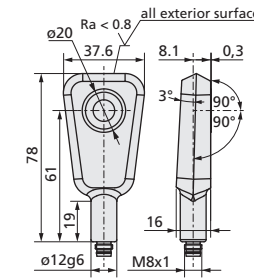

**blind zone**: 20 mm  
**operating range**: 150 mm  
**maximum range**: 250 mm  
**angle of beam spread**: see detection zone  
**transducer frequency**: 380 kHz  
**resolution**: 0.069 mm  
**reproducibility**: ±0.15 %  
**detection zones**  
 for different objects:  
 The dark grey areas represent the zone where it is easy to recognise the normal reflector (round bar). This indicates the typical operating range of the sensors. The light grey areas represent the zone where a very large reflector – for instance a plate – can still be recognised. The requirement here is for an optimum alignment to the sensor. It is not possible to evaluate ultrasonic reflections outside this area.

<b>blind zone</b>	20 mm
<b>operating range</b>	150 mm
<b>maximum range</b>	250 mm
<b>angle of beam spread</b>	see detection zone
<b>transducer frequency</b>	380 kHz
<b>resolution</b>	0.069 mm
<b>reproducibility</b>	±0.15 %

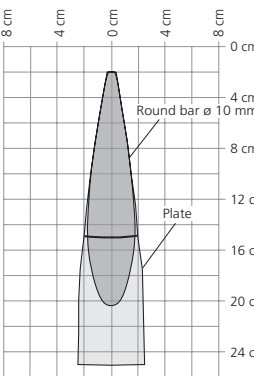

<b>blind zone</b>	30 mm
<b>operating range</b>	250 mm
<b>maximum range</b>	350 mm
<b>angle of beam spread</b>	see detection zone
<b>transducer frequency</b>	320 kHz
<b>resolution</b>	0.069 mm
<b>reproducibility</b>	±0.15 %

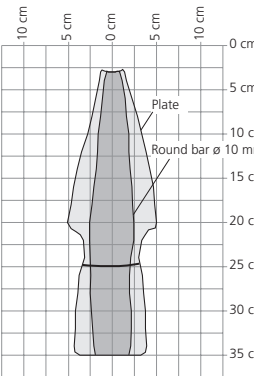

<b>blind zone</b>	70 mm
<b>operating range</b>	350 mm
<b>maximum range</b>	600 mm
<b>angle of beam spread</b>	see detection zone
<b>transducer frequency</b>	400 kHz
<b>resolution</b>	0.069 mm
<b>reproducibility</b>	±0.15 %

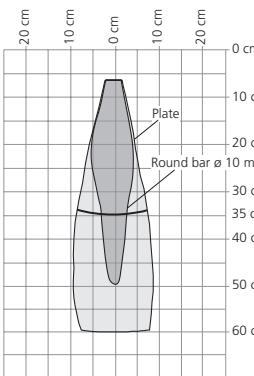

<b>blind zone</b>	120 mm
<b>operating range</b>	1,000 mm
<b>maximum range</b>	1,300 mm
<b>angle of beam spread</b>	see detection zone
<b>transducer frequency</b>	200 kHz
<b>resolution</b>	0.069 mm
<b>reproducibility</b>	±0.15 %

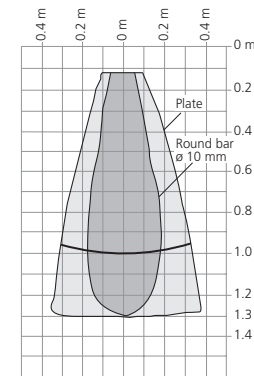

<b>accuracy</b>	±1 % (temperature drift internal compensated, may be deactivated <sup>1)</sup> , 0.17%/K without compensation)
<b>operating voltage U<sub>B</sub></b>	10 to 30 V DC, reverse polarity protection (Class 2)
<b>voltage ripple</b>	±10 %
<b>no-load current consumption</b>	<40 mA
<b>housing</b>	stainless steel 1.4404/316L; ultrasonic transducer: PTFE, FKM
<b>ECOLAB</b>	yes
<b>EHEDG</b>	TYPE EL CLASS I AUX
<b>norm conformity</b>	EN 60947-5-2
<b>class of protection to EN 60529</b>	IP 66, IP 67, IP 68
<b>type of connection</b>	4-pin M8 initiator plug
<b>controls</b>	Teach-in via pin 2 (Com)
<b>scope of setting</b>	Teach-in, LinkControl, IO-Link
<b>cleaning temperature</b>	up to +85 °C
<b>operating temperature</b>	-25 to +70 °C
<b>storage temperature</b>	-40 to +85 °C
<b>switching hysteresis <sup>1)</sup></b>	2 mm
<b>switching frequency <sup>2)</sup></b>	25 Hz
<b>response time <sup>2)</sup></b>	32 ms
<b>time delay before availability</b>	<300 ms
<b>weight</b>	140 g

<b>accuracy</b>	±1 % (temperature drift internal compensated, may be deactivated <sup>1)</sup> , 0.17%/K without compensation)
<b>operating voltage U<sub>B</sub></b>	10 to 30 V DC, reverse polarity protection (Class 2)
<b>voltage ripple</b>	±10 %
<b>no-load current consumption</b>	<40 mA
<b>housing</b>	stainless steel 1.4404/316L; ultrasonic transducer: PTFE, FKM
<b>ECOLAB</b>	yes
<b>EHEDG</b>	TYPE EL CLASS I AUX
<b>norm conformity</b>	EN 60947-5-2
<b>class of protection to EN 60529</b>	IP 66, IP 67, IP 68
<b>type of connection</b>	4-pin M8 initiator plug
<b>controls</b>	Teach-in via pin 2 (Com)
<b>scope of setting</b>	Teach-in, LinkControl, IO-Link
<b>cleaning temperature</b>	up to +85 °C
<b>operating temperature</b>	-25 to +70 °C
<b>storage temperature</b>	-40 to +85 °C
<b>switching hysteresis <sup>1)</sup></b>	3 mm
<b>switching frequency <sup>2)</sup></b>	25 Hz
<b>response time <sup>2)</sup></b>	32 ms
<b>time delay before availability</b>	<300 ms
<b>weight</b>	140 g

<b>accuracy</b>	±1 % (temperature drift internal compensated, may be deactivated <sup>1)</sup> , 0.17%/K without compensation)
<b>operating voltage U<sub>B</sub></b>	10 to 30 V DC, reverse polarity protection (Class 2)
<b>voltage ripple</b>	±10 %
<b>no-load current consumption</b>	<40 mA
<b>housing</b>	stainless steel 1.4404/316L; ultrasonic transducer: PTFE, FKM
<b>ECOLAB</b>	yes
<b>EHEDG</b>	TYPE EL CLASS I AUX
<b>norm conformity</b>	EN 60947-5-2
<b>class of protection to EN 60529</b>	IP 66, IP 67, IP 68
<b>type of connection</b>	4-pin M8 initiator plug
<b>controls</b>	Teach-in via pin 2 (Com)
<b>scope of setting</b>	Teach-in, LinkControl, IO-Link
<b>cleaning temperature</b>	up to +85 °C
<b>operating temperature</b>	-25 to +70 °C
<b>storage temperature</b>	-40 to +85 °C
<b>switching hysteresis <sup>1)</sup></b>	5 mm
<b>switching frequency <sup>2)</sup></b>	12 Hz
<b>response time <sup>2)</sup></b>	64 ms
<b>time delay before availability</b>	<300 ms
<b>weight</b>	140 g

<b>accuracy</b>	±1 % (temperature drift internal compensated, may be deactivated <sup>1)</sup> , 0.17%/K without compensation)
<b>operating voltage U<sub>B</sub></b>	10 to 30 V DC, reverse polarity protection (Class 2)
<b>voltage ripple</b>	±10 %
<b>no-load current consumption</b>	<40 mA
<b>housing</b>	stainless steel 1.4404/316L; ultrasonic transducer: PTFE, FKM
<b>ECOLAB</b>	yes
<b>EHEDG</b>	TYPE EL CLASS I AUX
<b>norm conformity</b>	EN 60947-5-2
<b>class of protection to EN 60529</b>	IP 66, IP 67, IP 68
<b>type of connection</b>	4-pin M8 initiator plug
<b>controls</b>	Teach-in via pin 2 (Com)
<b>scope of setting</b>	Teach-in, LinkControl, IO-Link
<b>cleaning temperature</b>	up to +85 °C
<b>operating temperature</b>	-25 to +70 °C
<b>storage temperature</b>	-40 to +85 °C
<b>switching hysteresis <sup>1)</sup></b>	20 mm
<b>switching frequency <sup>2)</sup></b>	10 Hz
<b>response time <sup>2)</sup></b>	80 ms
<b>time delay before availability</b>	<300 ms
<b>weight</b>	140 g

<b>accuracy</b>	±1 % (temperature drift internal compensated, may be deactivated <sup>1)</sup> , 0.17%/K without compensation)
<b>operating voltage U<sub>B</sub></b>	10 to 30 V DC, reverse polarity protection (Class 2)
<b>voltage ripple</b>	±10 %
<b>no-load current consumption</b>	<40 mA
<b>housing</b>	stainless steel 1.4404/316L; ultrasonic transducer: PTFE, FKM
<b>ECOLAB</b>	yes
<b>EHEDG</b>	TYPE EL CLASS I AUX
<b>norm conformity</b>	EN 60947-5-2
<b>class of protection to EN 60529</b>	IP 66, IP 67, IP 68
<b>type of connection</b>	4-pin M8 initiator plug
<b>controls</b>	Teach-in via pin 2 (Com)
<b>scope of setting</b>	Teach-in, LinkControl, IO-Link
<b>cleaning temperature</b>	up to +85 °C
<b>operating temperature</b>	-25 to +70 °C
<b>storage temperature</b>	-40 to +85 °C
<b>switching hysteresis <sup>1)</sup></b>	20 mm
<b>switching frequency <sup>2)</sup></b>	10 Hz
<b>response time <sup>2)</sup></b>	80 ms
<b>time delay before availability</b>	<300 ms
<b>weight</b>	140 g

**order no.** pms-15/CF/A1  
**switching output** push-pull, U<sub>B</sub>=3 V, -U<sub>B</sub>+3 V, I<sub>max</sub> = 100 mA switchable NOC/NCC, short-circuit-proof

**order no.** pms-25/CF/A1  
**switching output** Push-Pull, U<sub>B</sub>=3 V, -U<sub>B</sub>+3 V, I<sub>max</sub> = 100 mA switchable NOC/NCC, short-circuit-proof

**order no.** pms-35/CF/A1  
**switching output** Push-Pull, U<sub>B</sub>=3 V, -U<sub>B</sub>+3 V, I<sub>max</sub> = 100 mA switchable NOC/NCC, short-circuit-proof

**order no.** pms-100/CF/A1  
**switching output** Push-Pull, U<sub>B</sub>=3 V, -U<sub>B</sub>+3 V, I<sub>max</sub> = 100 mA switchable NOC/NCC, short-circuit-proof

<sup>1)</sup> Can be programmed via LinkControl and IO-Link.  
<sup>2)</sup> With LinkControl and IO-Link, the selected filter setting and the maximum range influence the switching frequency and response time.