



Operating Manual

Ultrasonic proximity switch with one analogue output, one switching output and IO-Link

- lpc+15/CFU lpc+15/WK/CFU
- lpc+25/CFU lpc+25/WK/CFU
- lpc+35/CFU lpc+35/WK/CFU
- lpc+100/CFU lpc+100/WK/CFU

Product Description

The lpc+ sensor offers a non-contact measurement of the distance to an object which must be positioned within the sensor's detection zone. The switching output is set conditional upon the adjusted switching distance. A distance-proportional analogue signal is output depending on the set window limits. Via the Teach-in procedure, the detect distance and operating mode can be adjusted. The states of the switching and analogue output are each indicated by two LEDs (green/yellow).

IO-Link

The lpc+ sensor is IO-Link-capable in accordance with IO-Link specification V1.1 and supports Smart Sensor Profile like Digital Measuring Sensor. The sensor can be monitored and parameterized via IO-Link.

Safety instructions

- Read the operating manual prior to start-up.
- Connection, installation and adjustments may only be carried out by qualified staff.
- No safety component in accordance with the EU Machine Directive, use in the area of personal and machine protection not permitted

Proper Use

lpc+ ultrasonic sensors are used for non-contact detection of objects.

Installation

- Mount the sensor at the place of fitting.
- Connect a connection cable to the M12 device plug, see Fig. 1.



microsonic notation	IO-Link notation	IO-Link Smart Sensor Profile	colour
1 +U _b	L+		brown
2 U	U	ASC1	white
3 -U _b	L-		blue
4 F	C/Q	SSC1	black
5 Com	NC		grey

Fig. 1: Pin assignment with view onto sensor plug, IO-Link notation and colour coding of the microsonic connection cables

Start-up

- Connect the power supply.
- Set the parameters of the sensor by using the Teach-in procedure, see Diagram 1.

Factory Settings

- Switching point operation
- Switching output on NOC
- Switching distance at operating range

- Rising analogue characteristic
- Window limits for the analogue output at maximum value of the blind zone and the operating range
- Input Com set to »Teach-in + Sync«
- Filter at F01
- Filter strength at P00

Operating modes

Three operating modes are available for the switching output:

- **Operation with one switching point**
The switching output is set when the object falls below the set switching point.
- **Window mode**
The switching output is set when the object is outside the window limits.
- **Two-way reflective barrier**
The switching output is set when the object is between sensor and fixed reflector.

Diagram 1: Set sensor parameters via the Teach-in procedure

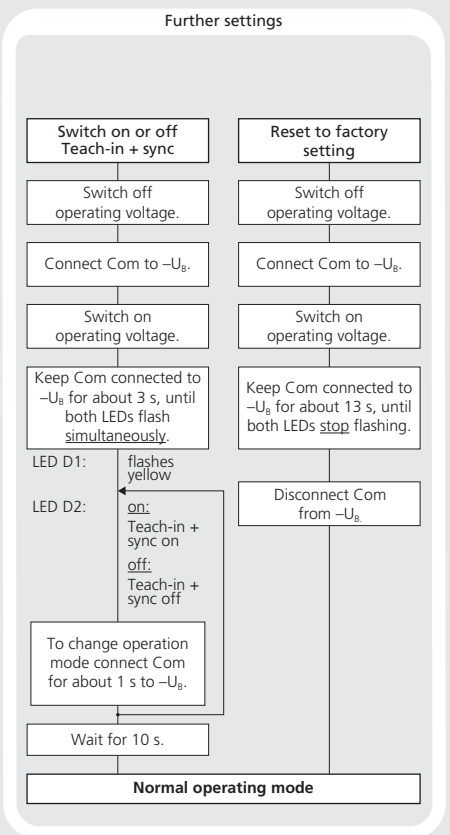
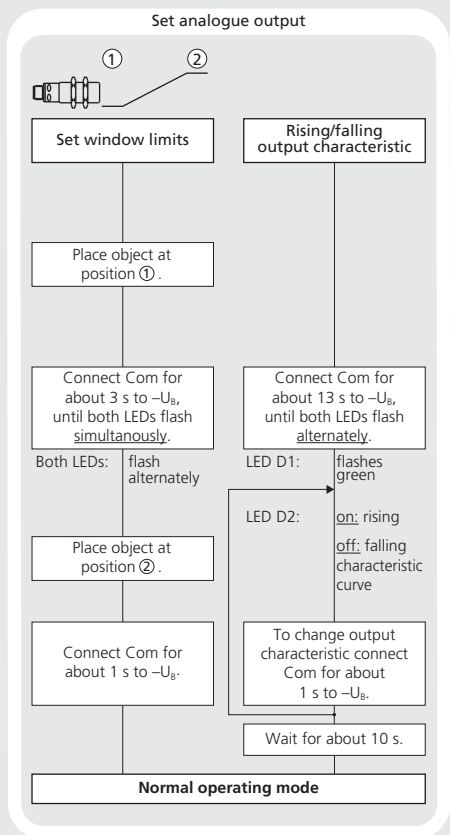
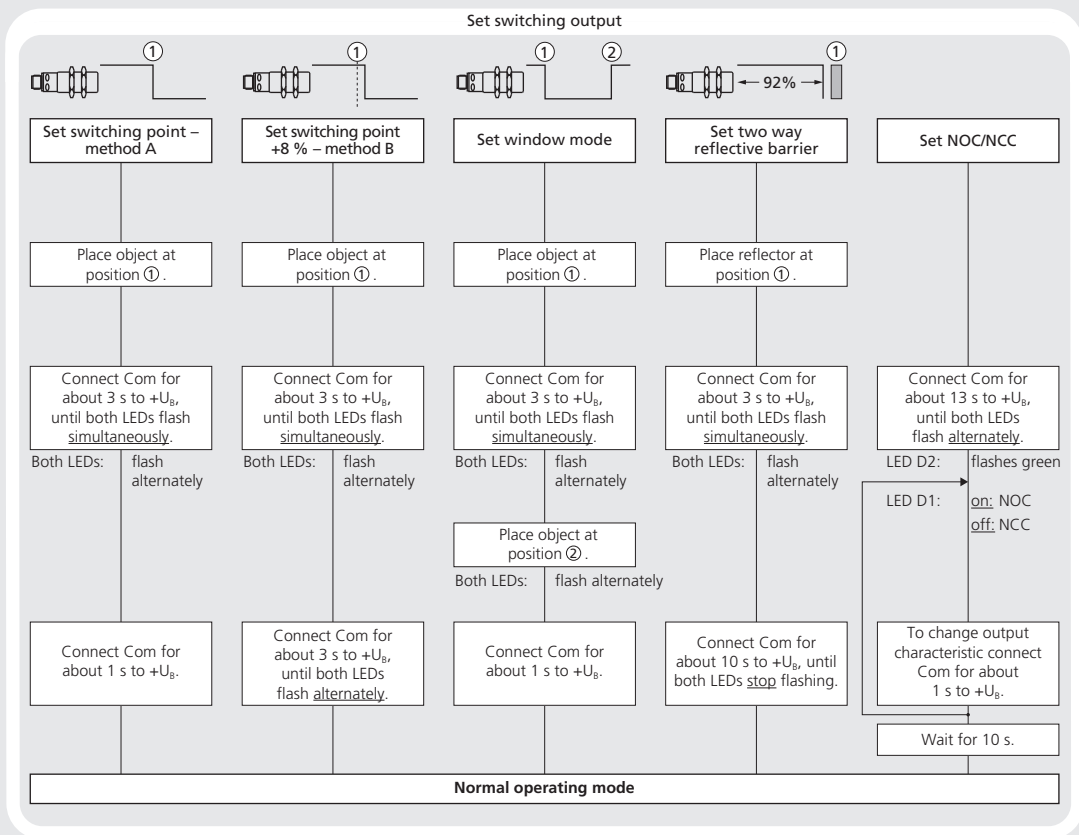

Technical Data

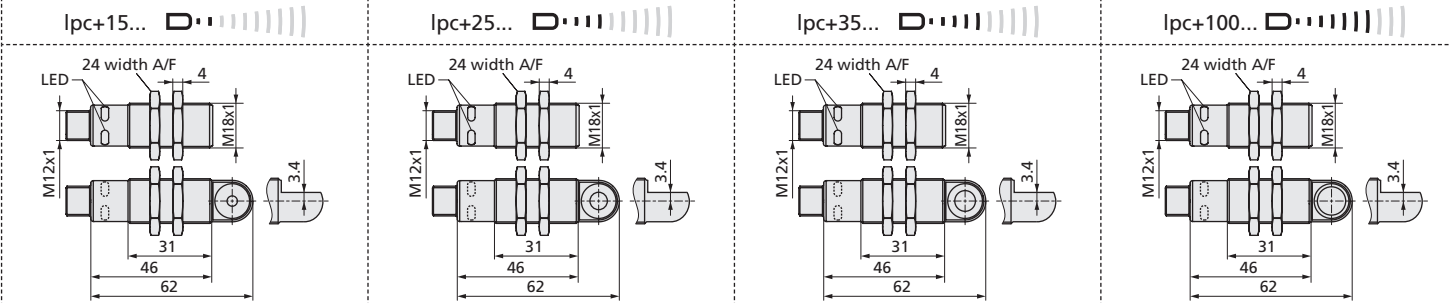
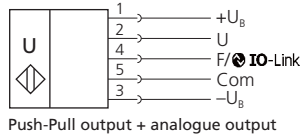

blind zone	0 to 20 mm	0 to 30 mm	0 to 65 mm	0 to 120 mm
operating range	150 mm	250 mm	350 mm	1,000 mm
maximum range	250 mm	350 mm	600 mm	1,300 mm
angle of beam spread	see detection zone	see detection zone	see detection zone	see detection zone
transducer frequency	380 kHz	320 kHz	400 kHz	200 kHz
resolution IO-Link	0.1 mm	0.1 mm	0.1 mm	0.1 mm
resolution analogue output	0.1 mm	0.1 mm	0.1 to 0.17 mm, depending on the analogue window	0.1 to 0.37 mm, depending on the analogue window

reproducibility	±0.15 %	±0.15 %	±0.15 %	±0.15 %
------------------------	---------	---------	---------	---------

detection zones
for different objects:
The dark grey areas represent the zone where it is easy to recognise the normal reflector (round bar). This indicates the typical operating range of the sensors. The light grey areas represent the zone where a very large reflector – for instance a plate – can still be recognised. The requirement here is for an optimum alignment to the sensor. It is not possible to evaluate ultrasonic reflections outside this area.

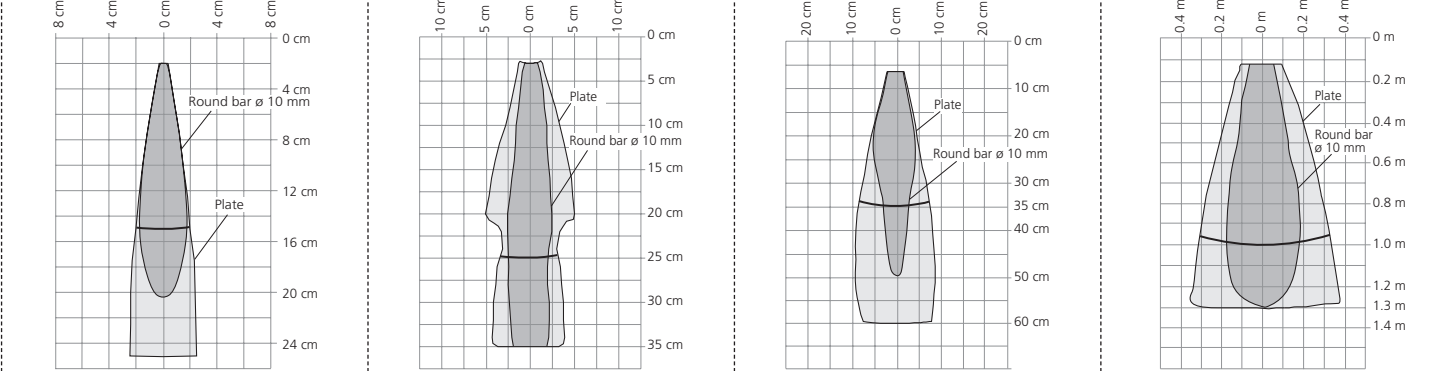

accuracy	±1 % (temperature drift internally compensated)	±1 % (temperature drift internally compensated)	±1 % (temperature drift internally compensated)	±1 % (temperature drift internally compensated)
voltage ripple	±10 %	±10 %	±10 %	±10 %
no-load current consumption	<50 mA	<50 mA	<50 mA	<50 mA
housing	brass sleeve, nickel-plated, plastic parts: PBT; ultrasonic transducer: polyurethane foam, epoxy resin with glass content	brass sleeve, nickel-plated, plastic parts: PBT; ultrasonic transducer: polyurethane foam, epoxy resin with glass content	brass sleeve, nickel-plated, plastic parts: PBT; ultrasonic transducer: polyurethane foam, epoxy resin with glass content	brass sleeve, nickel-plated, plastic parts: PBT; ultrasonic transducer: polyurethane foam, epoxy resin with glass content
max. tightening torque of nuts	15 Nm	15 Nm	15 Nm	15 Nm
class of protection per EN 60529	IP 67	IP 67	IP 67	IP 67
norm conformity	EN 60947-5-2	EN 60947-5-2	EN 60947-5-2	EN 60947-5-2
type of connection	5-pin M12 circular plug	5-pin M12 circular plug	5-pin M12 circular plug	5-pin M12 circular plug
controls	Teach-in via pin 5 (Com)	Teach-in via pin 5 (Com)	Teach-in via pin 5 (Com)	Teach-in via pin 5 (Com)
scope for settings	Teach-in, LinkControl, IO-Link	Teach-in, LinkControl, IO-Link	Teach-in, LinkControl, IO-Link	Teach-in, LinkControl, IO-Link
IO-Link	V1.1	V1.1	V1.1	V1.1
indicators	2 x LED green, 2 x LED yellow	2 x LED green, 2 x LED yellow	2 x LED green, 2 x LED yellow	2 x LED green, 2 x LED yellow
synchronisation	internal synchronisation up to 10 sensors	internal synchronisation up to 10 sensors	internal synchronisation up to 10 sensors	internal synchronisation up to 10 sensors
operating temperature	-25 to +70 °C	-25 to +70 °C	-25 to +70 °C	-25 to +70 °C
storage temperature	-40 to +85 °C	-40 to +85 °C	-40 to +85 °C	-40 to +85 °C
switching hysteresis 1)	2 mm	3 mm	5 mm	20 mm
switching frequency 2)	25 Hz	25 Hz	12 Hz	10 Hz
response time 2)	32 ms	32 ms	64 ms	80 ms
time delay before availability	<300 ms	<300 ms	<300 ms	<300 ms
switching output	Push-Pull, $U_B = 3\text{ V}$, $-U_B = 3\text{ V}$, $I_{max} = 100\text{ mA}$ switchable NOC/NCC, short-circuit-proof	Push-Pull, $U_B = 3\text{ V}$, $-U_B = 3\text{ V}$, $I_{max} = 100\text{ mA}$ switchable NOC/NCC, short-circuit-proof	Push-Pull, $U_B = 3\text{ V}$, $-U_B = 3\text{ V}$, $I_{max} = 100\text{ mA}$ switchable NOC/NCC, short-circuit-proof	Push-Pull, $U_B = 3\text{ V}$, $-U_B = 3\text{ V}$, $I_{max} = 100\text{ mA}$ switchable NOC/NCC, short-circuit-proof
analogue output 0 to 10 V	$R_t \geq 100\text{ k}\Omega$, rising/falling characteristic	$R_t \geq 100\text{ k}\Omega$, rising/falling characteristic	$R_t \geq 100\text{ k}\Omega$, rising/falling characteristic	$R_t \geq 100\text{ k}\Omega$, rising/falling characteristic
operating voltage U_B	$R_t \geq 100\text{ k}\Omega$ at $U_B \geq 15\text{ V}$, short-circuit-proof terminal reverse polarity protected, Class 2	$R_t \geq 100\text{ k}\Omega$ at $U_B \geq 15\text{ V}$, short-circuit-proof terminal reverse polarity protected, Class 2	$R_t \geq 100\text{ k}\Omega$ at $U_B \geq 15\text{ V}$, short-circuit-proof terminal reverse polarity protected, Class 2	$R_t \geq 100\text{ k}\Omega$ at $U_B \geq 15\text{ V}$, short-circuit-proof terminal reverse polarity protected, Class 2
order no. directly radiating	lpc+15/CFU	lpc+25/CFU	lpc+35/CFU	lpc+100/CFU
weight	35 g	35 g	35 g	35 g
order no. angular head	lpc+15/WK/CFU	lpc+25/WK/CFU	lpc+35/WK/CFU	lpc+100/WK/CFU
weight	40 g	40 g	40 g	40 g

1) Can be programmed via LinkControl and IO-Link.

2) With LinkControl and IO-Link, the selected filter setting influences the switching frequency and response time.



Synchronisation

If the assembly distance of multiple sensors falls below the values shown in Fig. 2, the internal synchronisation should be used («Teach-in + sync» must be switched on, see Diagram 1). For this purpose set the switching and analogue outputs of all sensors in accordance with Diagram 1. Finally interconnect each pin 5 of the sensors to be synchronised.



		
lpc+15...	≥0.25 m	≥1.30 m
lpc+25...	≥0.35 m	≥2.50 m
lpc+35...	≥0.40 m	≥2.50 m
lpc+100...	≥0.70 m	≥4.00 m

Fig. 2: Minimal assembly distances without synchronisation

Maintenance

microsonic sensors are maintenance-free. In case of excess caked-on dirt we recommend cleaning the white sensor surface.

Notes

- Pin 5 (Com) of the sensor may only be connected during Teach-in procedures or for synchronisation.
- The sensors of the lpc+ family have a blind zone, within which a distance measurement is not possible.
- The lpc+ sensors are equipped with an internal temperature compensation. Due to the sensors self heating, the temperature compensation reaches its optimal working point after approx. 120 seconds of operation.
- In the normal operating mode, an illuminated yellow LED D2 signals that the related switching output is set.
- In the normal operating mode, an illuminated yellow LED D1 signals that the object is within the analogue window limits.
- In IO-Link mode, the green LED D2 flashes.

- In the »Two-way reflective barrier« operating mode, the object has to be within the range of 0 to 92 % of the set distance.
- In the »Set switching point – method A« Teach-in procedure the actual distance to the object is taught to the sensor as the detect point. If the object moves towards the sensor (e.g. with level control) then the taught distance is the level at which the sensor has to switch the output, see Fig. 3.

- If the object to be scanned moves into the detection area from the side, the »Set switching point +8 % – method B« Teach-in procedure should be used. In this way the switching distance is set 8 % further than the actual measured distance to the object.

This ensures a reliable switching behavior even if the height of the objects varies slightly, see Fig. 3.

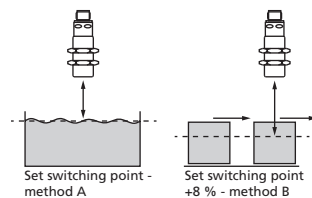

Fig. 3: Setting the switching point for different directions of movement of the object

- The sensor can be reset to its factory setting (see »Further settings«).
- The lpc+ sensor can be blocked against changes in the sensor via function »Switch on or off Teach-in + sync«, see Diagram 1.
- Using the LinkControl adapter LCA-2 (optional accessory) and the LinkControl software for Windows®, all Teach-in and additional sensor parameter can be optionally adjusted.
- The latest IODD file and informations about start-up and configuration of lpc+ sensors via IO-Link, you will find online at:
<https://www.microsonic.de/en/lpc+>